







48 V  
Li-ion

12V  
AGM

-  Zračni meh
-  Plinski generator
-  Zateznik varnostnega pasu
-  Krmilna enota za pomožni omejevalni sistem SRS
-  Plinski blažilnik/prednapeta vzmet
-  Nizkovoltni akumulator
-  Bencin rezervoar za gorivo

Napotek: Za več informacij si oglejte naš [reševalni vodnik](#).



## 1. Identifikacija / prepoznavanje



2

**G 450 d**

3

**G 500**

4

**G 550**

## 2. Imobilizacija / stabilizacija / dvig

### Ročna zavora

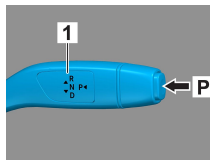
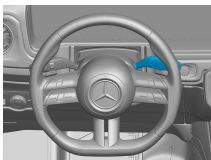

### Parkirna zavora

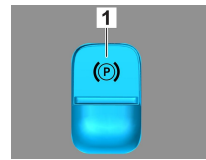
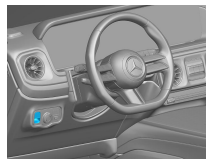

Pritisnite stikalo P na izbirni ročici (1). Ročna zavora se aktivira samodejno.

Električna parkirna zavora (1)

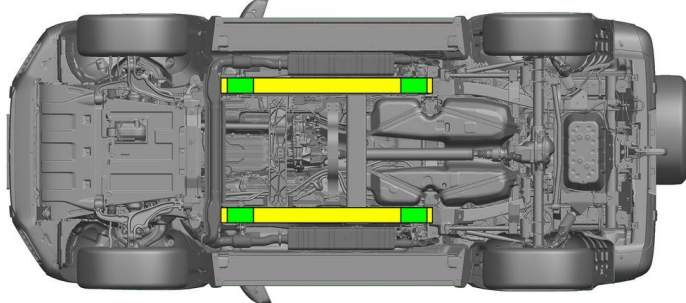

Ustrezne dvizne točke



Ustrezne stabilizacijske točke na strani



Preprečiti je treba dodatne deformacije pragov in podvozja med reševanjem (npr. s podporo s hidravlično opremo).

## 3. Onemogočanje neposrednih nevarnosti / varnostni predpisi

### Izklop vžiga:

1. Pritisnite tipko START-STOP brez aktiviranja delovne zavor.
2. Elektronski ključ vozila hranite na razdalji najmanj 5 m.

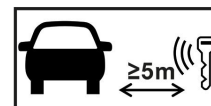

Odsotnost hrupa motorja ne pomeni, da je vozilo izklopljeno.



Ponovni zagon je možen, dokler vozilo ne preneha delovati.



### Odklop 48-voltnega akumulatorja

1. Demontirajte talno ploščo prtljažnika (odvijte 4 pritrdilna ušesca), nato demontirajte različne obloge (stebriček C, stebriček D, karoserijski rob itd.) ter oblogo stranske stene, da zagotovite dostop do 48-voltnega akumulatorja.

2. Sprostite negativni kabel 48-voltnega akumulatorja na vijaknem spoju in ga zavarujte pred neželenim kontaktom.





### Odklop 12-voltnega akumulatorja



1. Demontirajte talno ploščo prtljažnika (odvijte 4 pritrdilna ušesca), da zagotovite dostop do 12-voltnega akumulatorja.
2. Sprostite negativni kabel 12-voltnega akumulatorja na vijačnem spoju in ga zavarujte pred neželenim kontaktom.



Pasivni varnostni sistemi (zračne blazine in zategovalniki varnostnega pasu) se deaktivirajo.

### 4. Dostop do potnikov

Pri osvobajanju potnikov je treba upoštevati predele karoserije iz visoko trdnega jekla in sestavne dele zadrževalnih sistemov (zlasti pirotehnične elemente) v skladu z navedbami na strani 1.

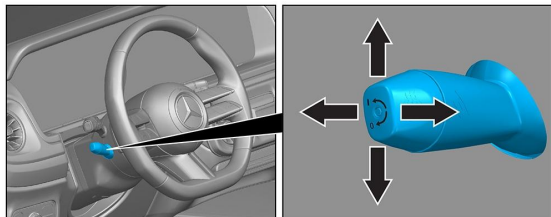

Nastavitev volana

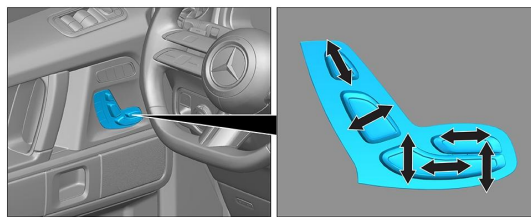

Nastavitev sedeža (električna)



- VSG: laminirano varnostno steklo
- ESG: enoslojno varnostno steklo

### 5. Shranjena energija / tekočine / plini / trdne snovi

		12 V/ 48 V
		100 L
		100 L
		680 ± 10 g

### 6. V primeru požara



Za gašenje požara v vozilu uporabite velike količine vode (H<sub>2</sub>O).

### 7. V primeru potopitve

Ni nevarnosti, da bi na karoseriji prišlo do napetosti. Po reševanju vozila:

1. Pustite, da voda iz notranjosti odteče.
2. Zaženite deaktivacijo 12/48-V električnega sistema vozila (glejte poglavje 3).



## 8. Vleka / prevoz / shranjevanje

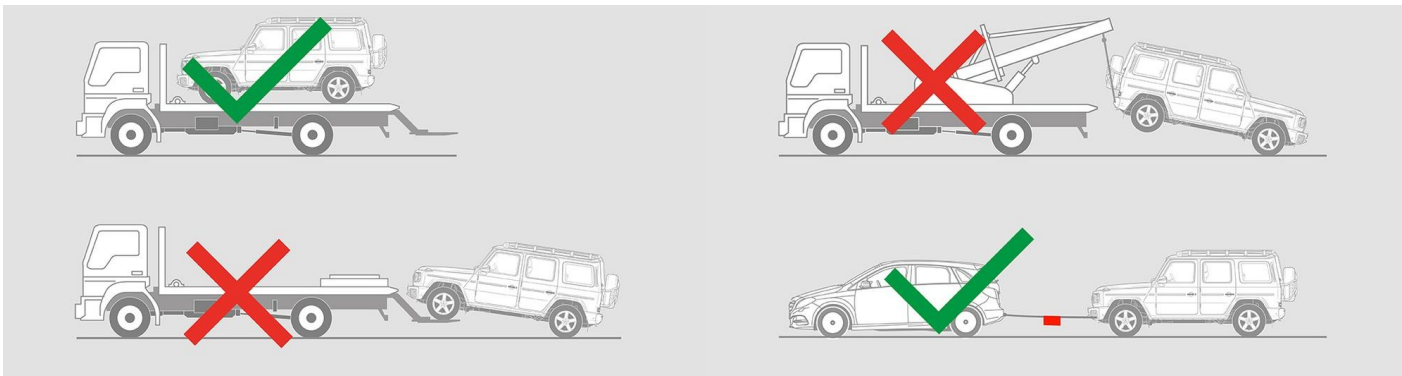

## 9. Pomembne dodatne informacije

Nadaljnje informacije najdete v [Vodniku vlečne službe za osebna vozila](#).

## 10. Razlaga uporabljenih piktogramov



Vozilo na tekoče gori-  
vo skupine 1



Vozilo na tekoče gori-  
vo skupine 2



Splošen opozorilni  
znak



Vnetljivo



Nevarnost za zdravje  
ljudi



Jedke snovi



Akutna strupenost



Eksplozivno



Za gašenje požara  
uporabite vodo



Za gašenje požara  
uporabite suho peno



Za gašenje požara  
uporabite vlažno peno



Prtljažnik



Odstranite pametni  
ključ



Komponenta za klimat-  
sko napravo



Opozorilo; nizka teme-  
ratura