

-  Kollisjonspute
-  Gassgenerator
-  Beltestrammer
-  SRS styreenhet
-  Gasstrykkdemper / Forspent fjær
-  Lavvolt-batteri
-  Høyvolt-batteri
-  Høyvolt-kabel
-  Høyvolt-komponenter
-  Alternativ innretning for utkobling av høyspenning
-  Høyspenningsskillepunkt (lavspenningsselement)

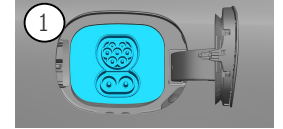

1. Identifisering / Gjenkjenning



2. Immobilisering / stabilisering / løfting

Parkeringsbrems

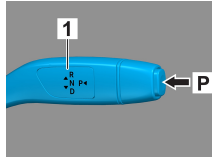
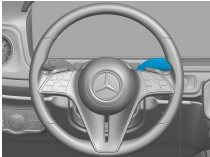

Trykk på bryter P på girvelgeren (1).
Parkeringsbremsen aktiveres automatisk.

Håndbrems

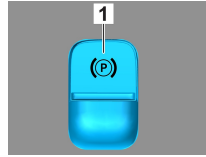
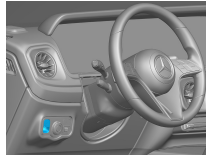

Elektrisk håndbrems (1)

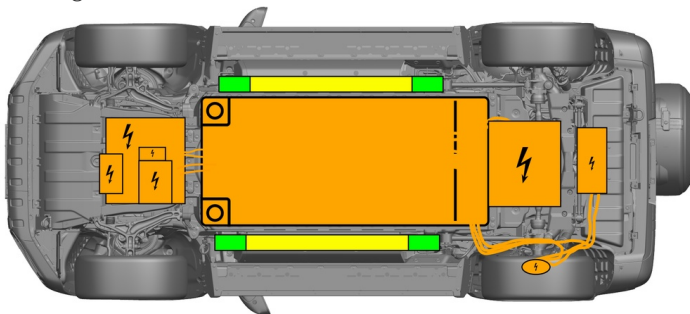

- Eget løftepunkt
- Eget stabilisering på siden
- Høyspenningssystem



En ekstra misforming av travers og underrammen må unngås under bergingen (f.eks. gjennom å støtte med hydraulikkutstyr).

3. Deaktivere direkte farer / sikkerhets regler

Slå tenningen av:

- Trykk på START-STOPP-knappen, uten å aktivere motorbremsen.
- Oppbevar den elektroniske bilnøkkelen i en avstand på minst 5 m.



Selv om du ikke kan høre om motoren går, betyr ikke dette at bilen er slått av.



Bilen kan starte på nytt, helt til den settes ut av drift.

Deaktivere høyspenningssystemet



Ved ulykker der airbagger og beltestrømmere har utløst slås høyspenningssystemet av automatisk.



I alle andre tilfeller skal høyspenningssystemet deaktiveres som følger:

Alternativ 1: Innretning for utkobling av høyspenning

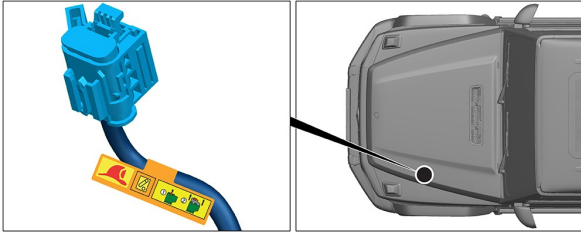

Høyvolt-utkoblingsanordningen er plassert i motorrommet på førersiden.

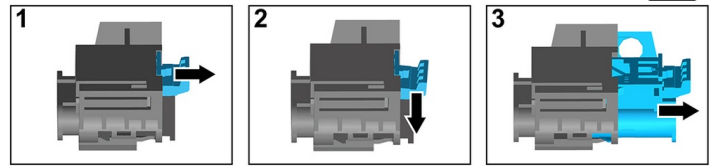

- (1) Trekk i frigjøringsmekanismen
- (2) Trykk frigjøringsmekanismen nedover
- (3) Trekk ut bryteren

Alternativ 2: Alternativ innretning for utkobling av høyspenning

Den alternative høyvoltutkoblingsanordningen befinner seg bak i A-søylen på passasjersiden. Den er merket med et informasjonsskilt.

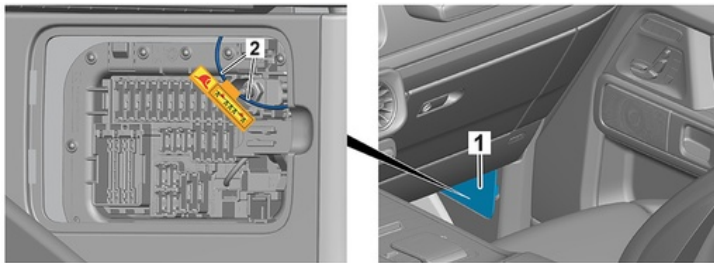

Fjern dekselet (1). Kapp ledningen på det markerte stedet (2).



Vent i ca. 20 sekunder etter utkobling for å sikre at det ikke ligger restspenning i høyspenningsnett.



De passive sikkerhetssystemene, som airbagger og beltestrammere, forsynes fremdeles med spenning via ledningsnett på 12 V.



Koble fra 12 V-batteriet

1. Fjern dekselet til 12 V-batteriet i bagasjerommet. Servicedekselet befinner seg i venstre sideledning.
2. Løsne minuskabelen til 12 V-batteriet ved skruforbindelsen og sikre den mot utilsiktet kontakt.

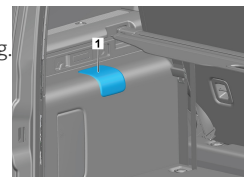

De passive sikkerhetssystemene (airbagger og beltestrammere) deaktiveres.

4. Tilgang til fører/passasjerer

Under redningen av personene i bilen skal man ta hensyn til komponentene til passasjersikringssystemet (spesielt pyrotekniske elementer) i henhold til opplysningene på side 1.

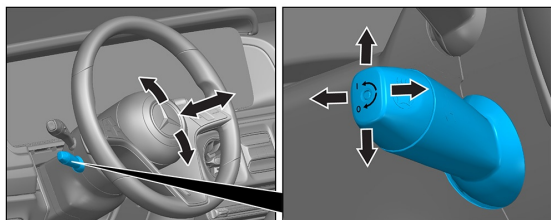

Rattinnstilling

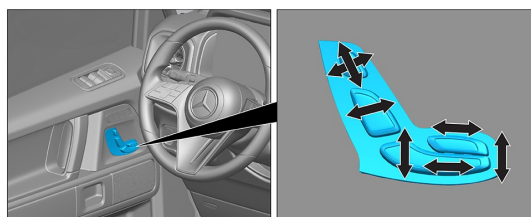

Seteinstilling (elektrisk)

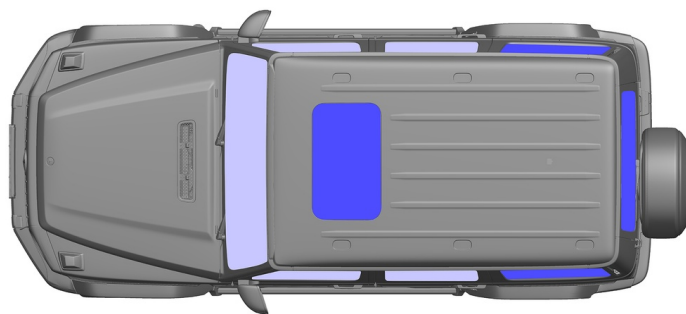

VSG: Laminert sikkerhetsglass

ESG: Herdet sikkerhetsglass

5. Lagret energi / væske / gass / fast

	 	12 V AGM
	 	400 V
	 	750 ± 10 g



Alle høyspenningsledninger er forsynt med en orasjefarget isolasjon.

6. I tilfelle brann



Bruk store mengder vann (H₂O) når du slukker en bilbrann.
Bruk store mengder vann (H₂O) for å kjøle li-ionbatteriet.



Advarsel: Tenning av batteriet mulig



Når det siver ut kjølemiddel fra høyspenningsbatteriet, kan batteriet bli ustabil på grunn av termisk overbelastning.
Kontroller batteritemperaturen med et IR-varmebildkamera.



7. I tilfelle nedsenket i vann/sjø

Det foreligger ikke fare for at spenningen går over på karosseriet.

Etter at bilen er berget:

1. Slipp ut vannet fra bilens innside.
2. Begynn med å deaktivere høyspenningssystemet (se kapittel 3).



8. Tauing / transport / lagring

Bilen skal kun transporteres med begge akslene på en slepebil eller en biltransporter.

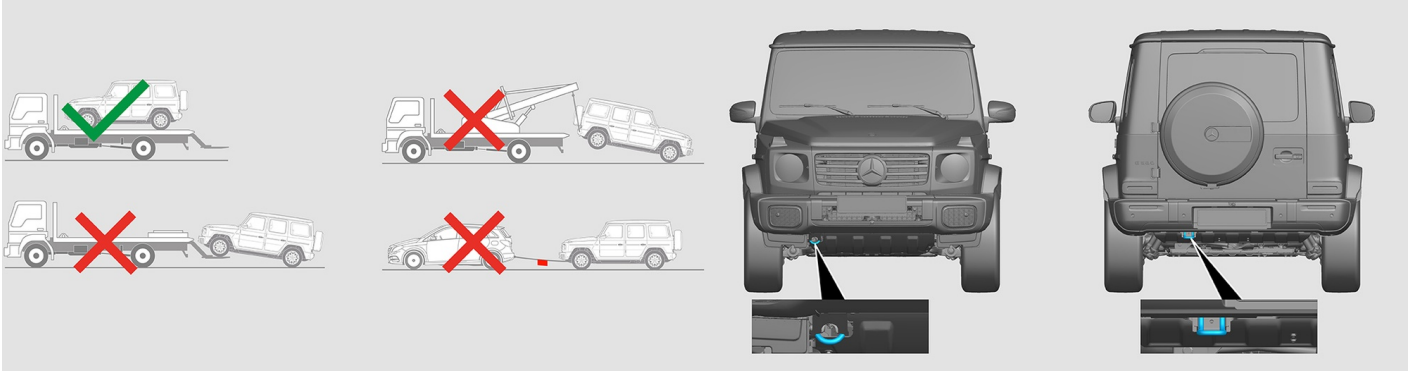

Oppbevares i sikker avstand til andre biler.

 Advarsel: Tenning av batteriet mulig 

9. Viktig ekstra informasjon

Mer informasjon finner du i [Veiledning for slepetjenester for sleping av personbil](#).

Merknad: Mer informasjon finner du i vår [bergingsveiledning](#).

10. Forklaring av piktogrammer

- | | | | |
|--|--|--|--|
|  Elkjøretøy |  Fare |  Fare! El. spenning! |  Brennbar |
|  Helsefarlig |  Korroderende |  Akutt toksisitet |  Eksplosiv |
|  Slukke med vann |  Bruk IR-varmebildekamera |  Panser |  Bagasjerom |
|  Fjern smartnøkkel |  Klimaanlegg |  Fare, lav temperatur | |