









-  Airbag
 -  Seat belt tensioner
 -  Fuel tank
 -  Restraint systems control unit
 -  12 V Battery
-
-  High-voltage battery
 -  High-voltage components
 -  High-voltage disconnect device

Note: Please see our [emergency response guide](#) for more information



1. Identification / recognition

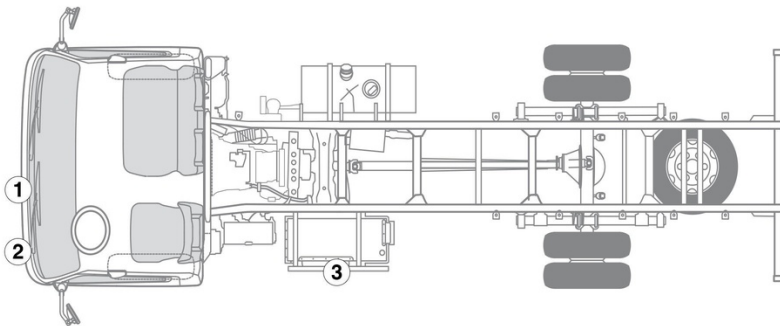

3. Disable direct hazards / safety regulations

Switch off the ignition:

1. To switch off the ignition, turn the ignition key to the ACC position (A)
2. Turn the ignition key further to the LOCK position (B) and remove it.

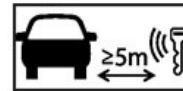

Deactivation of the high-voltage system

In all other cases, the high-voltage system should be deactivated as follows:

Option 1: High-voltage disconnect



The EMERGENCY OFF button is located in the cutout in the side panel of the high-voltage battery.

- Press the EMERGENCY OFF button



Option 2: Alternative high-voltage disconnect

The high-voltage disconnect device (safety plug) is located on the right-hand side of the high-voltage battery.

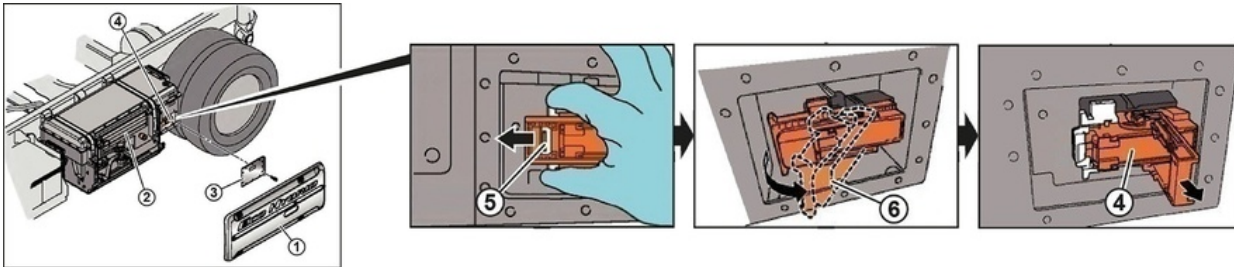

- Unscrew the 6 bolts (M8) and remove the side panel (1).
- Unscrew the 12 bolts (M6) and remove the cover (3) of the safety plug (4).
- Push the retainer (5) of the locking lever (6) to the left (arrow).
- Flip the locking lever (6) outwards.
- Pull the safety plug (4) out of the holder; it is now certain that the high-voltage circuit in the battery is interrupted.
- Reattach the cover (3) with 4 bolts in order to prevent the high-voltage system from being switched back on.



Danger from electrical voltage

If you commence rescue work before waiting for the capacitor to discharge, there is a danger of electric shock which could result in severe or fatal injuries. Before starting any rescue operations, wait for at least five minutes after switching off the high-voltage system in order to discharge the capacitor in the voltage converter.



In order to ensure that there is no longer any residual voltage in the high-voltage system, wait approx. 20 seconds after switching it off.



The passive safety systems such as airbags and seat belt pretensioners will continue to be supplied with power by the 12-volt electrical system.



Disconnecting the 12 V battery

1. Remove the cover from the 12-volt battery.
2. Disconnect the negative cable of the 12-volt battery at the screw connection and secure it against unintentional contact.