

① Bateria 12 V

② Bateria de alta voltagem

③ Dispositivo de corte de alta voltagem



Airbag



Pré-tensor do cinto de segurança



Reforço da carroceria



Unidade de comando dos sistemas de retenção



Bateria 12 V



Bateria de alta voltagem



Componentes de alta voltagem



Dispositivo de corte de alta voltagem

Indicação: Para mais informações, por favor consulte o nosso [guia de salvamento](#).



1. Identificação / reconhecimento

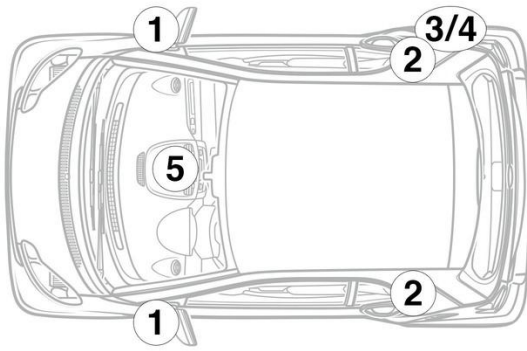

3. Neutralização dos principais perigos / regras de segurança

Desativação do sistema de alta voltagem

Em todos os outros casos, desativar o sistema de alta voltagem da seguinte forma:

Dispositivo de desconexão de alta voltagem



O dispositivo de corte de alta voltagem encontra-se na parte inferior do painel de instrumentos no sentido da marcha à esquerda.

Retirar a ficha (1) do suporte



Para garantir que não há tensão residual na rede de alta voltagem, aguardar cerca de 20 segundos após desligar.



Os sistemas de segurança passivos tais como airbags e pré-tensores de cintos de segurança continuam a ser alimentados com tensão pela rede de bordo de 12 volts.



Desconectar a bateria de 12 V

1. Retirar a cobertura das baterias de 12 volts.
2. Soltar o cabo negativo da bateria de 12 volts na união roscada e proteger contra contacto involuntário.