

① 12V 배터리

② 고전압 배터리

③ 고전압 차단장치

④ 윈도우 에어백(USA만 해당)



에어백



가스 발전기



안전벨트 텐서
너



가스 압력 댐퍼



구조 보강재



시트 안전 시스템 컨트롤 유닛



12V 배터리



고전압 배터리



고전압 부품

참고 사항: 자세한 내용은 [구조 안내서](#) 참조.



1. 식별/인식

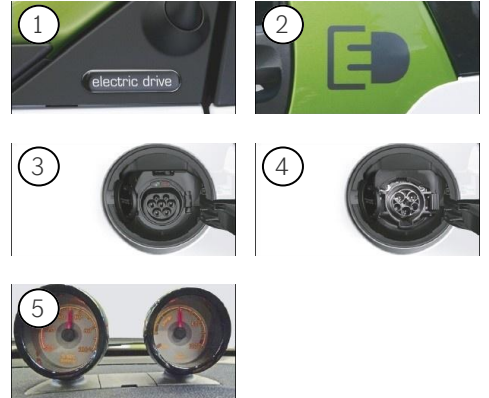
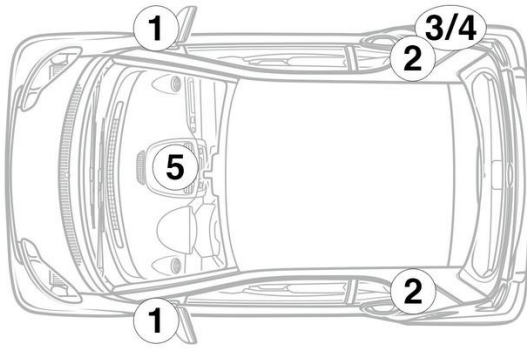

3. 직접적인 위험 제거 / 안전 규정 준수

고전압 시스템 비활성화

다른 모든 경우에는 다음과 같이 고전압 시스템을 비활성화해야 합니다.

고압 분리 장치



고전압 차단장치는 계기반 바닥면의 좌측(주행 방향)에 있습니다.

브래킷에서 커넥터(1) 분리



고전압 네트워크에 잔류 전압이 없는지 확인하려면 스위치를 끈 후 약 20초 동안 기다리십시오.



에어백 및 안전벨트 텐서너와 같은 수동 보안 시스템은 12V 차량 전원 시스템에 의해 계속해서 전원이 공급됩니다.



12V 배터리 분리

1. 12V 배터리 커버 제거.
2. 12V 배터리의 음극 케이블을 볼트 체결부에서 푼 후 의도치 않게 접촉되지 않도록 보호하십시오.