

- 
安全氣囊
- 
氣體產生器
- 
安全帶收緊裝置
- 
輔助保護系統 (SRS) 控制單元
- 
氣壓撐桿 / 氣動彈簧
- 
低電壓電瓶
- 
高電壓電瓶
- 
高壓電力電纜
- 
高壓組件
- 
電纜中斷
- 
斷開高電壓的低壓裝置

提醒: 詳細訊息請參考 [救援指南](#)。

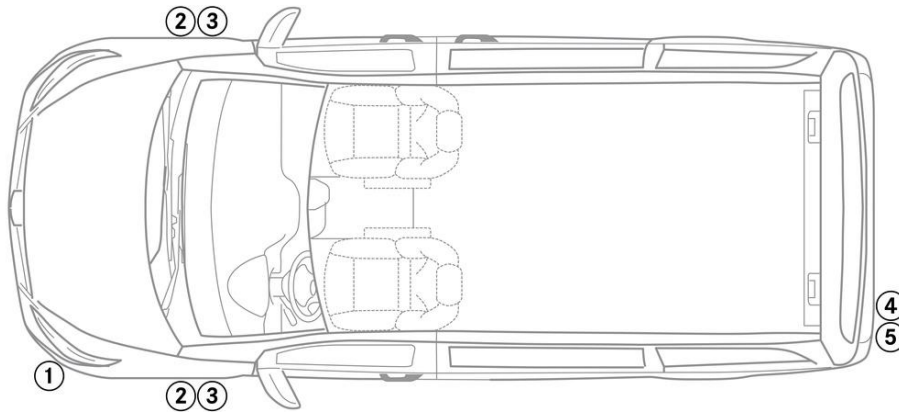

1. 確認/識別



2. 固定/穩定/升降

手煞車



駐車製動 – 根據車輛類型，按以下其中一種方式安裝：

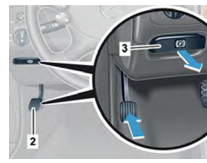

按下選檔桿 (1) 上的開關 P。電動手煞車即自動啟動。

1. 電動駐車製動器
2. 駐車製動踏板
3. 鬆開駐車製動按鈕
4. 駐車製動桿
5. 鬆開駐車製動桿按鈕

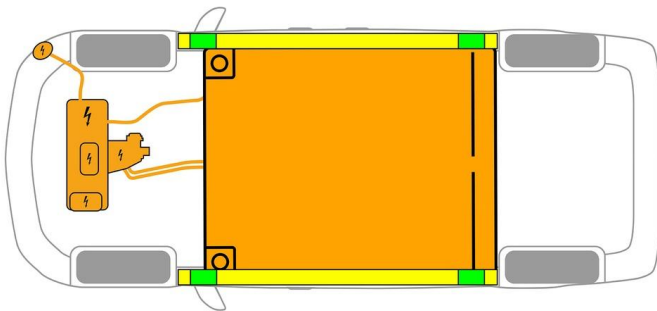

合適的升降點

高壓電池



救援期間必須避免車門門檻和車身底板發生額外的變形 (例如使用千斤頂支撐)。

3. 解除直接危害/安全規章

關閉點火開關：

1. 按下啟動/停止按鈕，而不要觸發主煞車。
2. 將電子車鑰匙放在至少 5 公尺之外。

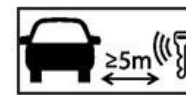

關閉點火開關：

1. 在點火鎖中逆時針轉動點火鑰匙，然後將其從點火鎖中拉出。
2. 從車輛上取下點火鑰匙。

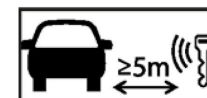

沒有引擎噪音並不表示車輛已關閉。



車輛關閉之前可以重新啟動。



停用高壓系統

! 若事故發生時觸發了安全氣囊和安全帶收緊裝置，將會自動關閉高壓系統。



在必要的狀況下，高壓系統應依照以下方式關閉：

選項 1: 高壓斷開裝置

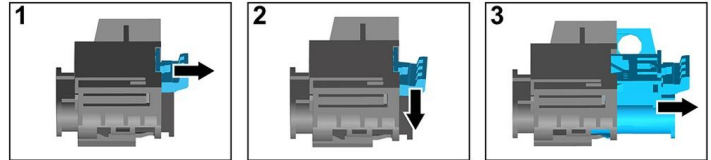
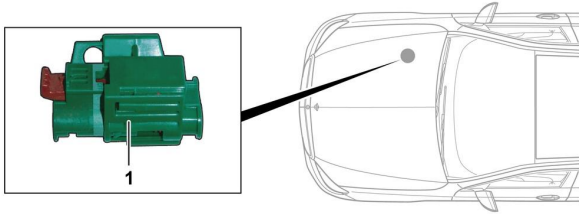

高壓斷開裝置位於 乘客側發動機 艙內。



- (1) 拉釋放
- (2) 向下推釋放
- (3) 拔出開關

選項 2: 替代高壓斷開裝置



替代高壓斷開裝置位於右前座的座椅底座上。它標有一個標誌。



拆下蓋子 (1)。穿過標記點 (2) 處的線。

! 為確保高壓網絡中沒有殘餘電壓，請在關閉後等待約 20 秒。

! 安全氣囊和安全帶張緊器等被動安全系統繼續由 12 伏車輛電氣系統供電。

斷開 12V 電池

- 1. 取下 12 伏電池蓋。
- 2. 鬆開螺絲連接處的 12 伏電池負極電纜，並防止意外接觸。

! 被動安全系統（安全氣囊和安全帶張緊器）被停用。



4. 救援通道

撤離乘客時，車體高強度鋼材以及抑制系統組件 (特別是高溫組件) 必須根據第 1 頁說明處理。

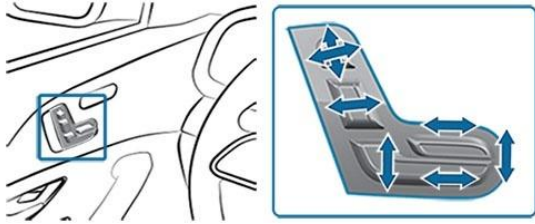

調整座椅 (電動)

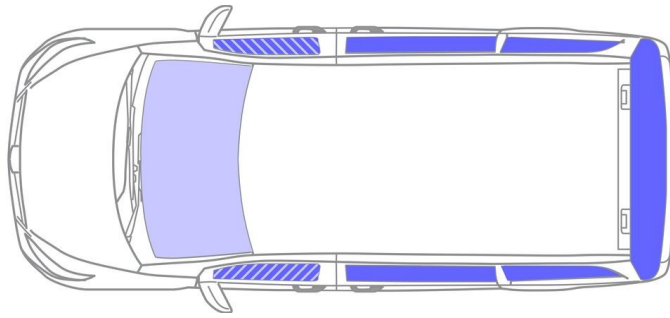

- VSG : 夾層安全玻璃
- ESG : 強化安全玻璃
- ESG / VSG

5. 剩餘電量/液體/燃油/固體



所有高壓電纜均具有橘色的絕緣層。

6. 車輛起火

使用大量的水 (H₂O) 滅火。
使用大量的水 (H₂O) 冷卻 電池。

警告：電池再次燃燒。



如果冷卻液從高壓電池洩漏，則冷卻液可能會由於熱過載而變得不穩定。使用紅外線熱像檢查電池溫度。



7. 車輛泡水

車身沒有通電的危險。拖吊車輛後：

1. 將車輛內的水排出。
2. 停用高壓系統 (參考第 3 章)



8. 拖吊/運輸/存放

運輸車輛時，車輛的四輪都必須位於拖吊車或運輸車輛上。



與其他車輛保持安全距離。

警告：電池再次燃燒。  

9. 其他重要訊息

更多訊息請參考 [拖吊服務指南](#)。

10. 使用圖示說明



電動車



注意 / 警告



電力警告



易燃物



對健康有害



腐蝕性物質



急性毒性



用水滅火



使用紅外線熱像儀



引擎蓋



移除智慧鑰匙