









- ① Fordonsbatteri
- ② Extrabatteri
- ③ Högvoltsbatteri
- ④ HV-laddningsuttag

 Krockkudde	 Gasgenerator	 Bältessträckare	 Styrenhet för säkerhetssystem	 Batteri 12 V
 Högvoltsbatteri	 Högvoltskomponenter	 Högvoltsbrytare	 Alternativ högvoltsbrytare	

Observera: Mer information finns i vår [räddningsguide](#).



1. Identifiering

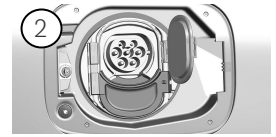
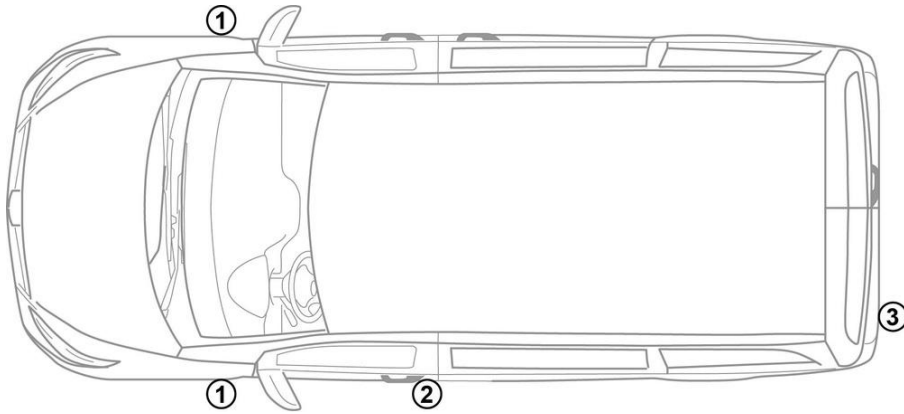

3. Oskadliggöra akuta risker/ säkerhetsföreskrifter

Inaktivering av högspänningssystem

I alla andra situationer ska högspänningssystemet inaktiveras så här:

Alternativ 1: Högspänningsfrånskiljare

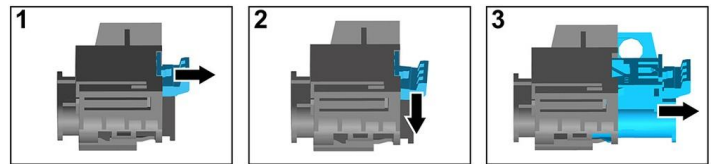
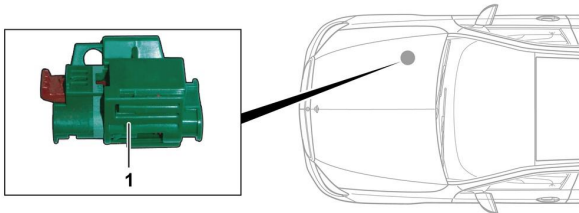

Högspänningsfrånskiljaren sitter i motorrummet på passagersidan.



- (1) Dra i spärren för upplåsning
- (2) Tryck spärren för upplåsning neråt
- (3) Dra ut strömbrytaren

Alternativ 2: Alternativ högspänningsfrånskiljare

Den alternativa högspänningsfrånskiljaren sitter under den högra framstolens sits. Den är märkt med en skylt.



Ta bort övertäckningen (1). Kapa ledningen på det markerade stället (2).



Koppla loss 12-voltsbatteriet

1. Ta bort övertäckningen från 12-voltsbatteriet.
2. Lossa minuskabeln från skruvförbandet på 12-voltsbatteriet och säkra den mot oavsiktlig kontakt.