











- ① Batteri 12 V
- ② Høyvoltbatteri
- ③ Høyvoltladekontakt
- ④ Innebygd lader
- ⑤ Tilleggsbatteri

 Kollisjonspute	 Gassgenerator	 Beltestrammer	 Gasstrykkdemper	 Drivstofftank
 Styreenhet kollisjonssikringssyst	 Batteri 12 V	 Hovedbatteri	 Høyvoltkomponenter	 Høyvoltutkoblingsanordning
 Alternativ høyvoltutkoblingsanordning				

Merknad: Mer informasjon finner du i vår [bergingsveiledning](#).



### 1. Identifisering / Gjennkjenning

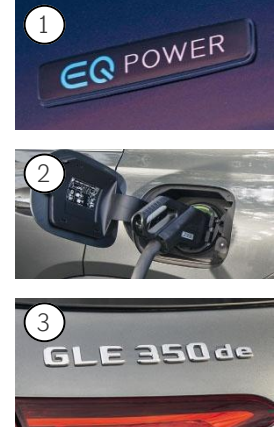
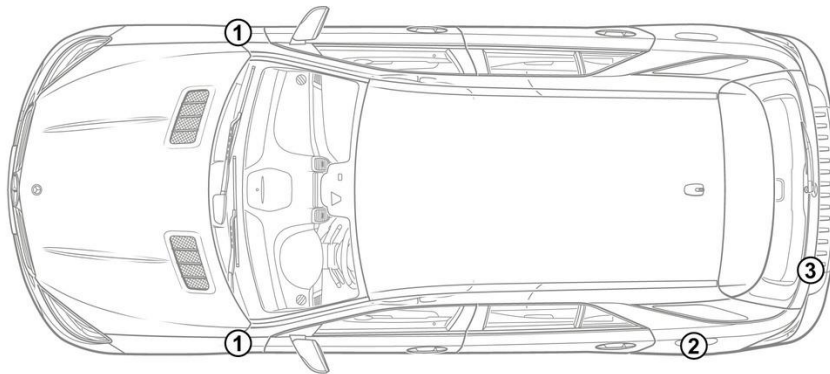

### 3. Deaktivere direkte farer / sikkerhets regler

#### Deaktivere høyspenningssystemet

I alle andre tilfeller skal høyspenningssystemet deaktiveres som følger:

#### Alternativ 1: Innretning for utkobling av høyspenning

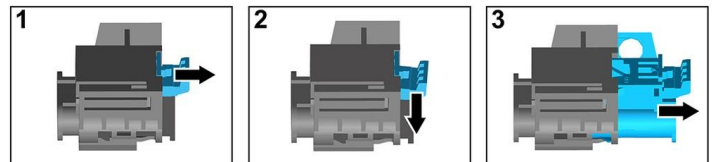
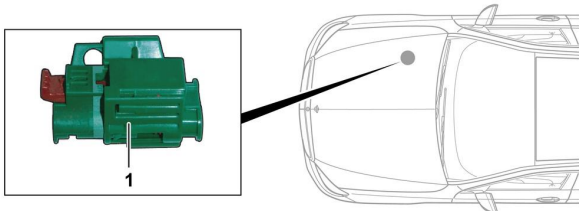

Innretningen for utkobling av høyspenning er plassert i motorrommet på passasjersiden.



- (1) Trekk i opplåsingsspaken
- (2) Trykk opplåsingsspaken nedover
- (3) Trekk ut bryteren

#### Alternativ 2: Alternativ innretning for utkobling av høyspenning

Den alternative innretningen for utkobling av høyspenning er plassert under dekselet til sikringsboksen på cockpiten på førersiden. Den er merket med et henvisningsskilt.

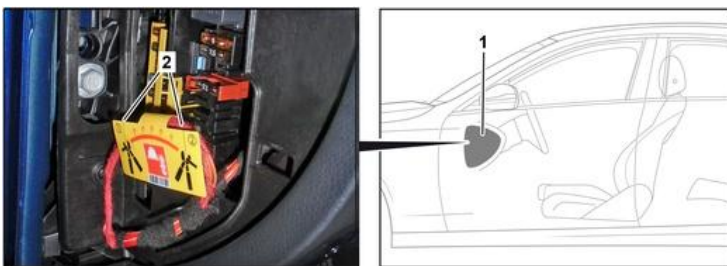

Fjern deksel (1) Kutt opp på markert punkt (2).



#### Klem av 12-V-batteriet

- 1. Fjern dekselet på 12-V-batteriet.
- 2. Løsne skruforbindelsen på minuskabelen til 12-V-batteriet, og sikre mot utilsiktet kontakt.