

① 차량 전원 배터리

② 보조 배터리

③ 고전압 배터리

④ 고전압 차단장치



에어백



가스 발전기



안전벨트 텐서
너



가스 압력 댐퍼



구조 보강재



연료 탱크



시트 안전 시스템
컨트롤 유닛



12V 배터리



고전압 배터리



고전압 부품



고전압 차단장
치

참고 사항: 자세한 내용은 [구조 안내서](#) 참조.



1. 식별/인식

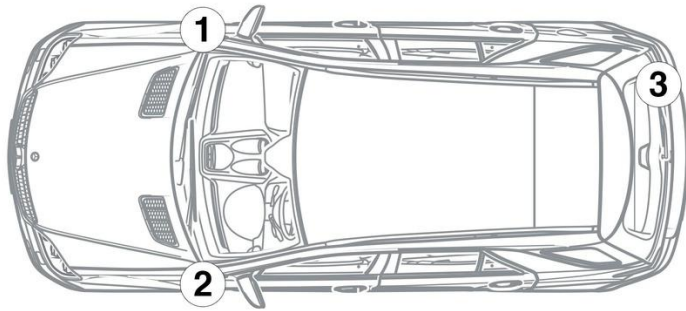

3. 직접적인 위험 제거 / 안전 규정 준수

고전압 시스템 비활성화

다른 모든 경우에는 다음과 같이 고전압 시스템을 비활성화해야 합니다.

옵션 1: 고압 분리 장치

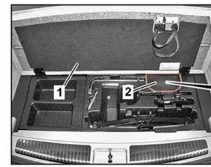

고전압 차단장치는 고전압 배터리 우측 후방(주행 방향)에 있습니다.



적재실 바닥(1) 올리기 / 커버(2) 제거 / 스위치(3)를 우측으로 민 후 고전압 배터리에서 분리



고전압 네트워크에 잔류 전압이 없는지 확인하려면 스위치를 끈 후 약 20초 동안 기다리십시오.



에어백 및 안전벨트 텐서너와 같은 수동 보안 시스템은 12V 차량 전원 시스템에 의해 계속해서 전원이 공급됩니다.



12V 배터리 분리

1. 12V 배터리 커버 제거.

2. 12V 배터리의 음극 케이블을 볼트 체결부에서 푼 후 의도치 않게 접촉되지 않도록 보호하십시오.