

① Batteria rete di bordo

② Batteria supplementare

③ Batteria ad alto voltaggio

④ Dispositivo di disinserimento alto voltaggio



Airbag

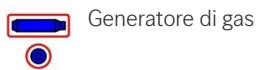

Generatore di gas

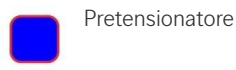

Pretensionatore

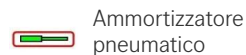

Ammortizzatore pneumatico

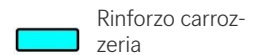

Rinforzo carrozzeria



Serbatoio carburante

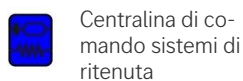

Centralina di comando sistemi di ritenuta

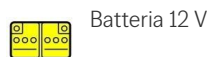

Batteria 12 V



Batteria ad alto voltaggio



Componenti per l'alto voltaggio

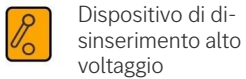

Dispositivo di disinserimento alto voltaggio

Nota: Ulteriori informazioni sono disponibili nelle nostre linee guida per il soccorso [linee guida per il soccorso](#)



1. Identificazione / riconoscimento

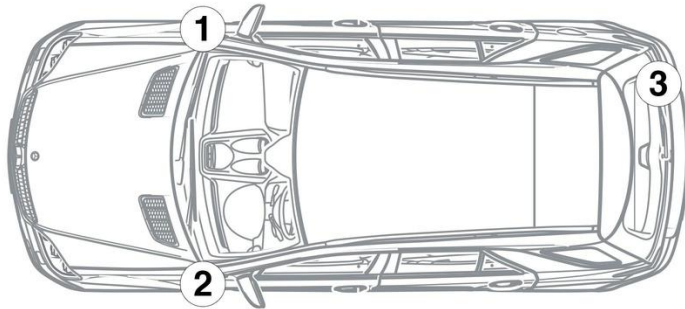

3. Disattivazione dei pericoli diretti / Regolamenti di Sicurezza

Disattivazione del sistema ad alto voltaggio

In tutti gli altri casi disattivare il sistema ad alto voltaggio come indicato di seguito:

Opzione 1: Dispositivo di disinserimento dell'alto voltaggio

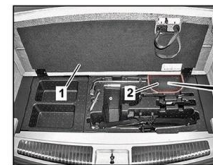

Il dispositivo di disinserimento alto voltaggio si trova in direzione di marcia nella parte posteriore destra sulla batteria ad alto voltaggio.



Sollevare il fondo del vano di carico (1) / Rimuovere la copertura (2) / Spingere l'interruttore (3) verso destra e staccarlo dalla batteria ad alto voltaggio



Per assicurare che nella rete dell'alta tensione non vi sia più tensione residua, dopo la disattivazione attendere circa 20 secondi.



I sistemi di sicurezza passivi, quali airbag e pretensionatori delle cinture di sicurezza, continuano a ricevere tensione tramite la rete di bordo a 12 volt.



Scollegare la batteria a 12 V

1. Rimuovere il coperchio della batteria a 12 Volt.

2. Scollegare il cavo negativo della batteria a 12 Volt nel raccordo a vite e metterlo in sicurezza contro un involontario contatto.