

- 
安全氣囊
- 
氣體產生器
- 
安全帶收緊裝置
- 
輔助保護系統 (SRS) 控制單元
- 
氣壓撐桿 / 氣動彈簧
- 
低電壓電瓶
- 
高電壓電瓶
- 
高壓電力電纜
- 
高壓組件
- 
電纜中斷
- 
斷開高電壓的低壓裝置

提醒: 詳細訊息請參考 [救援指南](#)。

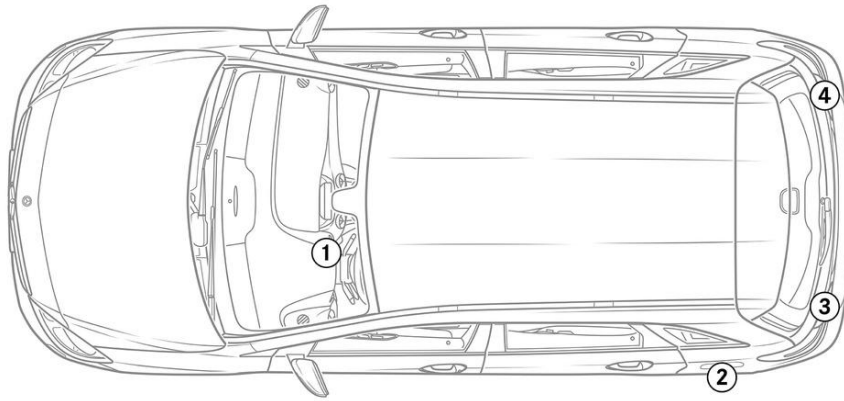

1. 確認/識別



3. 解除直接危害/安全規章

停用高壓系統

在必要的狀況下，高壓系統應依照以下方式關閉：

選項 1: 高壓斷開裝置



高電壓關閉裝置位在儀錶板左側飾板之後（以行車方向來看）

拆除儀錶板側飾板 (1) / 拔開插頭 (2)

選項 2: 替代高壓斷開裝置

替代高電壓關閉裝置位在右前座側腳部空間蓋板之下。並含注意事項標籤標記。

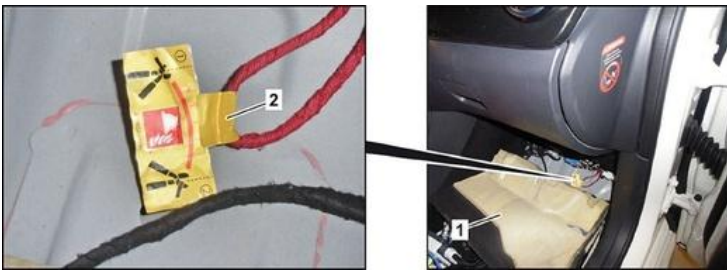

將腳部空間蓋板 (1) 朝後翻轉 / 在標示位置 (2) 處橫斷線路



為確保高壓網絡中沒有殘餘電壓，請在關閉後等待約 20 秒。



安全氣囊和安全帶張緊器等被動安全系統繼續由 12 伏車輛電氣系統供電。



斷開 12V 電瓶

1. 拆下引擎室內的 12 伏電池蓋。
2. 鬆開螺絲連接處的 12 伏電瓶負極電纜，並防止意外接觸。

