







-  Oro pagalvė
-  Dujų atsargų pripūtimo įtaisas
-  Saugos diržo įtempiklis
-  SRS valdymo blokas
-  Aktyvi pėsčiųjų apsaugos sistema
-  Dujų stovas / išankstinės apkrovos spyruoklės
-  Žemos įtampos akumuliatorius
-  Benzinas kuro bakas

Nurodymas: Daugiau informacijos rasite mūsų [gelbėjimo gairėse](#).



### 1. Identifikavimas / pripažinimas



### 2. Imobilizavimas / stabilizavimas / kėlimas

#### Stovėjimo stabdys

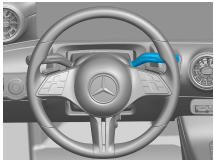

#### Stovėjimo stabdys

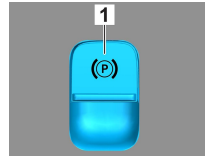

Paspauskite jungiklį P ant valdymo svirties (1).  
Stovėjimo stabdys įjungiamas automatiškai.

Elektrinis stovėjimo stabdys (1)

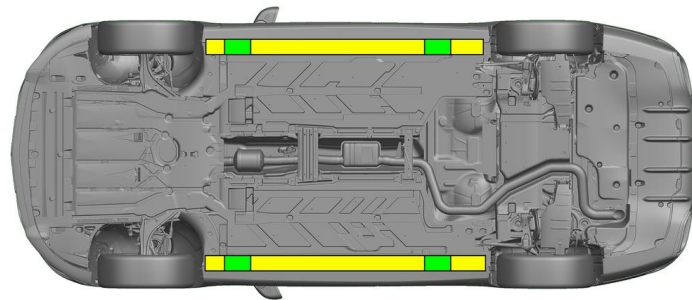

- Tinkami kėlimo taškai
- Tinkami stabilizavimo taškai šone



Gelbėjant reikia vengti papildomai deformuoti slenksčius ir dugną (pvz., atremiant su hidrauline įranga).

### 3. Atribokite tiesioginį pavojų / saugos taisyklės

#### Išjungti uždegimą:

1. Spauskite PALEIDIMO ir SUSTABDYMO mygtuką neįjungdami darbinio stabdžio.
2. Elektroninį transporto priemonės raktą laikykite ne arčiau kaip 5 m atstumu.

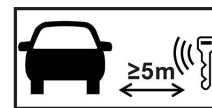

Jei nesigirdi variklio garsų, tai dar nereiškia, kad transporto priemonė yra išjungta.



Galima paleisti iš naujo iki baigiant naudoti transporto priemonę.



#### Atjungti 12 V / 48 V akumuliatorių

1. Nuimti 12 V / 48 V akumuliatoriaus dangtį.
2. Atjungti 12 V / 48 V akumuliatoriaus neigiamą gnybtą laidą prie varžtinio sujungimo ir apsaugoti nuo nepageidaujamo kontakto.



Pasyviosios saugos sistemos (oro pagalvės ir saugos diržų įtempikliai) išjungiamos.

#### 4. Prieiga keleiviams

Išlaisvinant keleivius, reikia atsižvelgti į įtempimo sistemų komponentus (ypač į pirotechnikos elementus) pagal 1 puslapyje pateiktus duomenis.

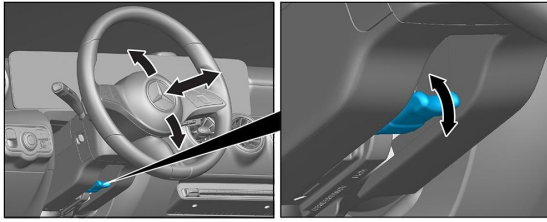

Vairo nustatymas

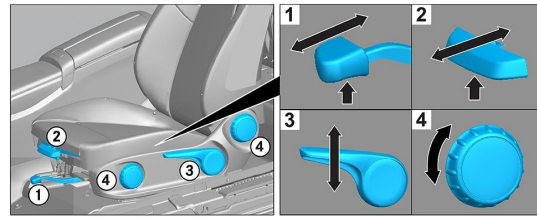

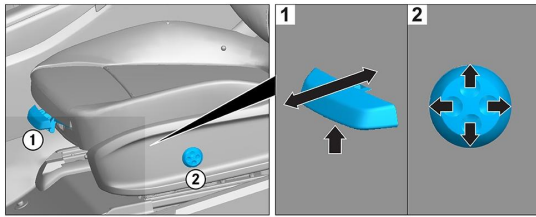

Sėdynės nustatymas (mechaninis)



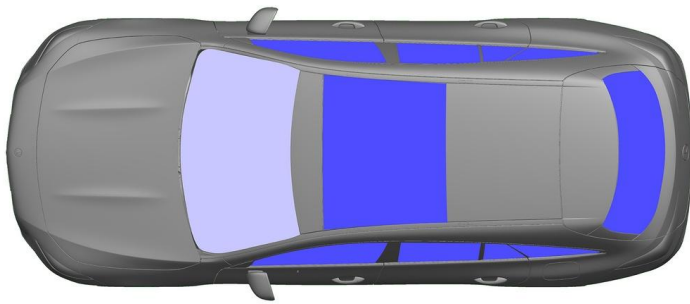











Sėdynės nustatymas (elektrinis)



 VSG: laminuotas stiklas

 ESG: grūdintas stiklas

#### 5. Sukauptoji energija / skysčiai / dujos / kietos medžiagos

	    	12 V / 48 V
	 	43 L
	  	530 ± 10 g

#### 6. Gaisro atveju



Transporto priemonės gaisrui gesinti reikia naudoti didelį vandens kiekį (H<sub>2</sub>O).

#### 7. Nugrimzdimo atveju

Nėra jokio pavojaus, kad kėbulas bus su įtampa. Po transporto priemonės gelbėjimo:

1. Vandeniui leisti ištekėti iš salono.
2. Išjungti 12 V / 48 V elektros sistemą (žr. 3 skyrių).



### 8. Vilkimas / gabenimas / sandėliavimas

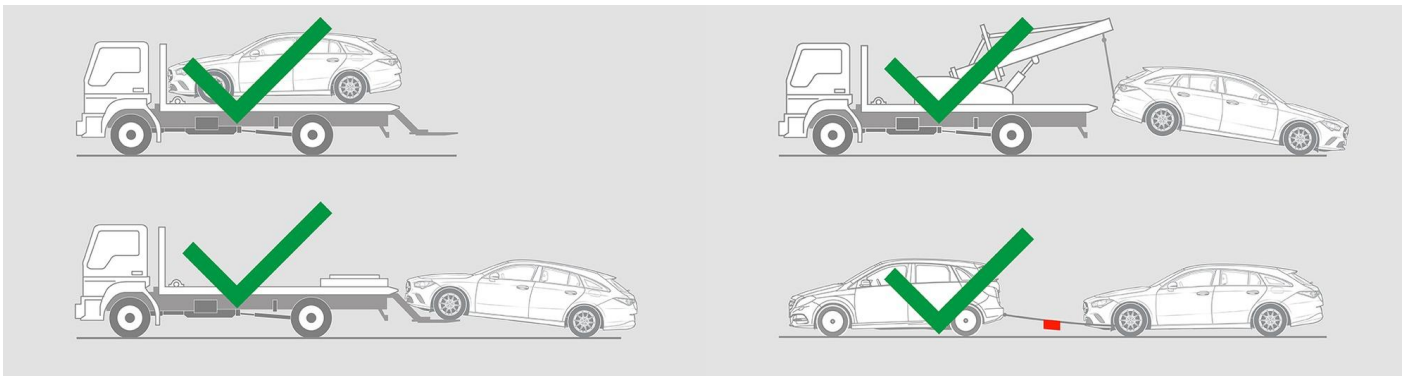

### 9. Svarbi papildoma informacija

Daugiau informacijos rasite [Gairės lengvųjų automobilių vilkimo tarnyboms](#).

### 10. Naudotų piktogramų paaiškinimas

-  Transporto priemonė, naudojanti 2-osios grupės skystąjį kurą
-  Bendrasis įspėjamasis ženklas
-  Degus
-  Pavojinga žmogaus sveikatai
-  Ėsdinančios medžiagos
-  Ūmus toksiškumas
-  Sprogus
-  Gaisrui gesinti naudokite vandenį
-  Gaisrui gesinti naudokite sausas putas
-  Gaisrui gesinti naudokite šlapias putas
-  Pašalinkite išmanųjį raktą
-  Oro kondicionavimo komponentas
-  Įspėjimas; žema temperatūra