

-  에어백
-  가스 발전기
-  안전벨트 텐서너
-  SRS 컨트롤 유닛
-  가스 압력 댐퍼/프리텐션 스프링
-  저전압 배터리
-  고전압 배터리
-  고전압 케이블
-  고전압 콤포넌트
-  대체 고전압 분리 장치
-  고전압 분리 지점 (저전압 요소)

참고 사항: 자세한 내용은 [구조 안내서](#) 참조.

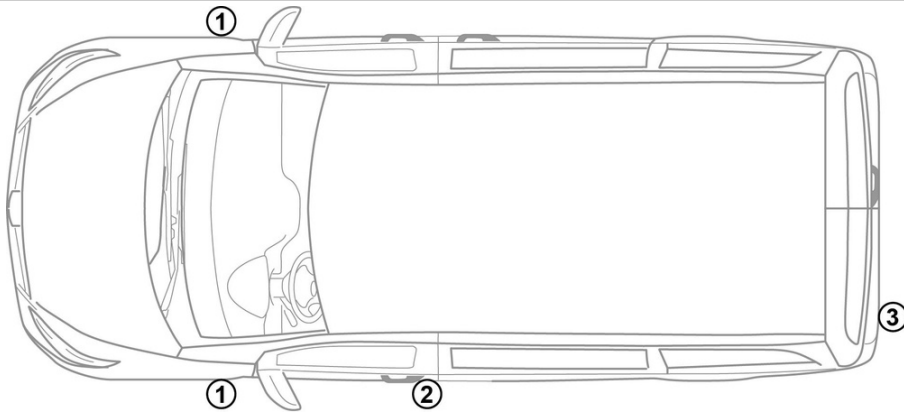

1. 식별/인식



①

ELECTRIC

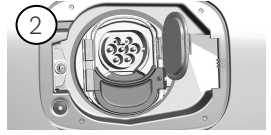

③

eVITO

3. 직접적인 위험 제거 / 안전 규정 준수

고전압 시스템 비활성화

다른 모든 경우에는 다음과 같이 고전압 시스템을 비활성화해야 합니다.

옵션 1: 고압 분리 장치

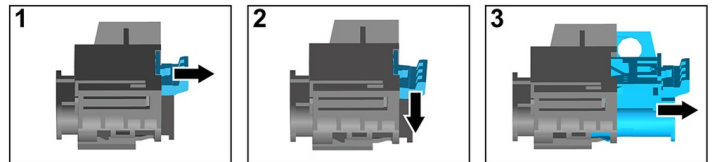
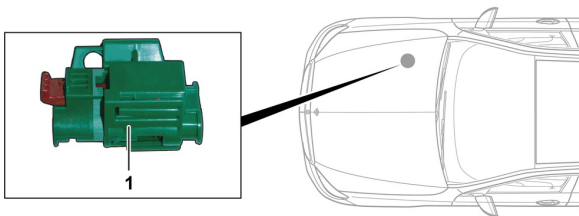

고전압 분리 장치는 주행 방향을 기준으로 엔진실 우측에 있습니다.



- (1) 잠금 해제 장치 당기기
- (2) 잠금 해제 장치 아래로 누르기
- (3) 스위치 당겨 빼기



옵션 2: 대체 고압 분리 장치

대체 고전압 분리 장치는 우측 앞좌석의 시트 베이스에 있습니다. 이 장치는 정보 라벨로 표시되어 있습니다.

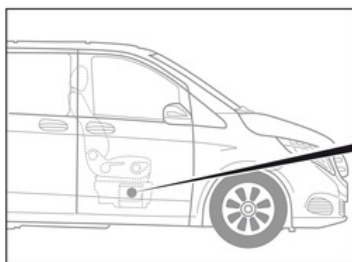

커버(1)를 제거하십시오. 표시된 지점(2)에서 라인을 절단하십시오.



12V 배터리 분리

- 1. 12V 배터리 커버 제거.
- 2. 12V 배터리의 음극 케이블을 볼트 체결부에서 푼 후 의도치 않게 접촉되지 않도록 보호하십시오.