













-  Zračni jastuk
-  Plinski generator
-  Zatezač sigurnosnog pojasa
-  SRS upravljački uređaj
-  Plinsko-hidraulični podupirač / zategnuta opruga
-  Niskonaponski akumulator
-  Benzin spremnik za gorivo
-  Visokonaponski akumulatorski paket
-  Visokonaponski električni kabel
-  Visokonaponska komponenta
-  Prekid kabela
-  Niskonaponski uređaj koji isključuje visoki napon

Napomena: Dodatne informacije potražite u našem [Vodiču za spašavanje](#).



1. Identifikacija

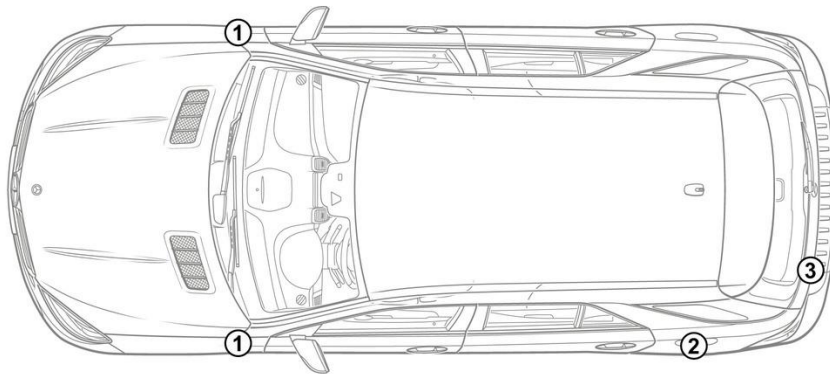

1

EQ POWER



3

GLE 350de

3. Sigurnosni propisi / izključivanje opasnosti

Deaktivacija visokonaponskog sustava

U svim drugim slučajevima deaktivirajte visokonaponski sustav kako slijedi:

Mogućnost 1: Naprava za isključivanje visokog napona

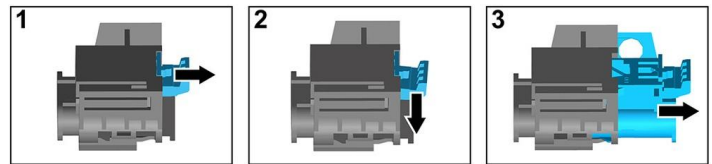
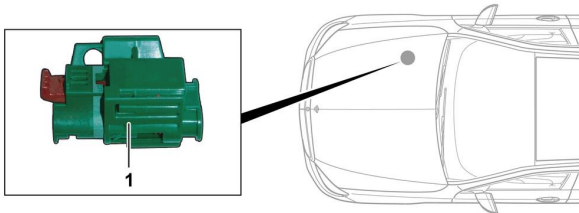

Naprava za isključivanje visokog napona nalazi se u prostoru motora na suvozačevoj strani.



- (1) Povucite deblokadu
- (2) Pritisnite deblokadu prema dolje
- (3) Izvucite sklopku



Mogućnost 2: Alternativna naprava za isključivanje visokog napona

Alternativna naprava za isključivanje visokog napona nalazi se ispod pokrova kutije s osiguračima na kokpitu na vozačevoj strani. Označena je natpisom.

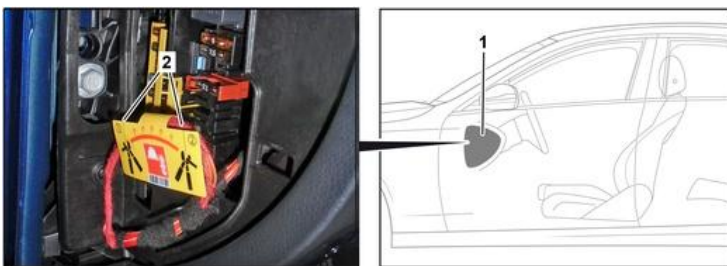

Uklonite pokrov (1). Prerežite vod na označenom mjestu (2).



Odvajanje akumulatora od 12 V

1. Uklonite pokrov akumulatora od 12 V
2. Otpustite minus kabel akumulatora od 12 V na vijčanom spoju i osigurajte ga od neželjenog kontakta.