

① Left-hand drive

② Right-hand drive

-  Zračni jastuk
-  Plinski generator
-  Zatezač sigurnosnog pojasa
-  SRS upravljački uređaj
-  Sustav aktivne zaštite pješaka
-  Plinsko-hidraulični podupirač / zategnuta opruga
-  Niskonaponski akumulator
-  Benzin spremnik za gorivo
-  Visokonaponski akumulatorski paket
-  Visokonaponski električni kabel
-  Visokonaponska komponenta
-  Prekid kabela
-  Niskonaponski uređaj koji isključuje visoki napon

Napomena: Dodatne informacije potražite u našem [Vodiču za spašavanje](#).



### 1. Identifikacija

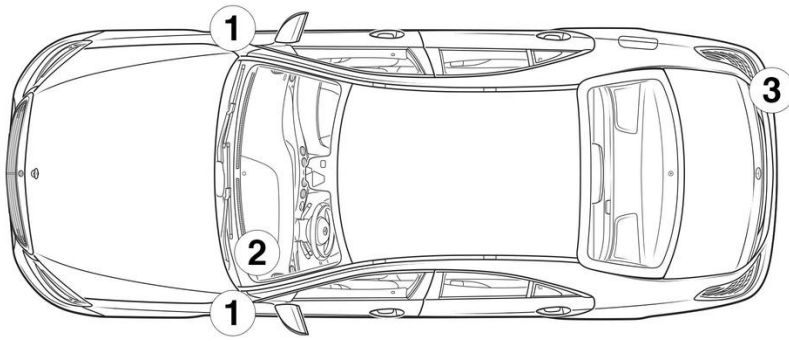

1

EQ POWER

2

整车型号 S 560 e L (222173)

3



### 2. Imobilizacija / stabilizacija / dizanje

Elektronička parkirna kočnica



Mehanička parkirna kočnica



Pritisnite sklopku P na ručici mjenjača (1). Automatski se aktivira elektronička parkirna kočnica.

Električna parkirna kočnica (1)

### 3. Sigurnosni propisi / izključivanje opasnosti

Isključivanje paljenja:

1. Pritisnite tipku za pokretanje/zaustavljanje bez aktivacije pogonske kočnice.
2. Pohanite elektronički ključ vozila na udaljenosti od najmanje 5 m.

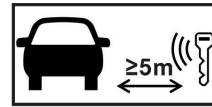

Samo zato što ne čujete zvukove motora, ne znači da je vozilo isključeno.



Vozilo je moguće ponovo pokrenuti dok ga ne stavite izvan pogona.

Deaktivacija visokonaponskog sustava



Visokonaponski sustav automatski se isključuje u slučaju nesreća kad se aktiviraju zračni jastuci ili zatezači sigurnosnih pojaseva.





U svim drugim slučajevima deaktivirajte visokonaponski sustav kako slijedi:

### Mogućnost 1: Naprava za isključivanje visokog napona

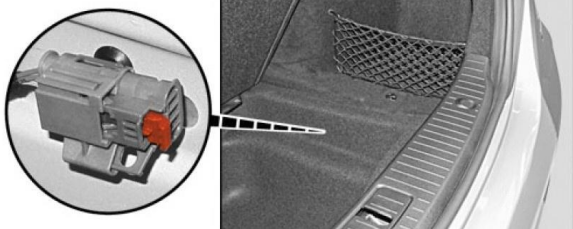

The high-voltage disconnect device is located on the right at the rear under the cover of the trunk recess. The recess lining is pulled out of the trunk by the tab below the trunk sill in the center of the vehicle.

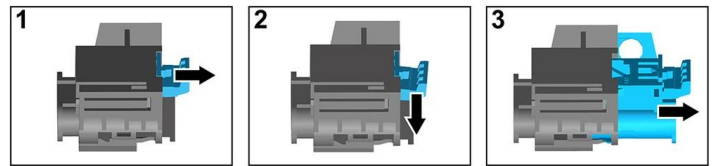

- (1) Pull the release
- (2) Push the release down
- (3) Pull out the switch

### Mogućnost 2: Alternativna naprava za isključivanje visokog napona



Alternativna naprava za isključivanje visokog napona nalazi se ispod pokrova kutije s osiguračima na kokpitu na vozačevoj strani.

Označena je natpisom.

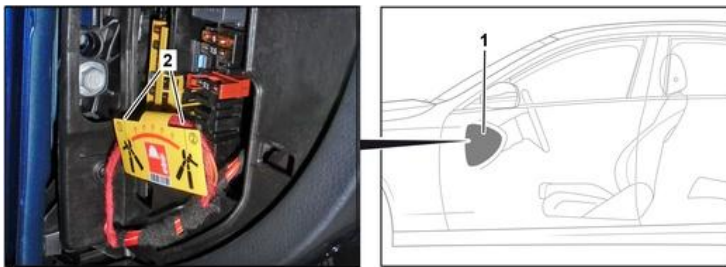

Uklonite pokrov (1). Prerežite vod na označenom mjestu (2).



Da biste osigurali da u visokonaponskoj mreži više nema preostalog napona, pričekajte cca 20 sekundi nakon isključivanja.



Unutarnja naponska mreža od 12 V i dalje naponom napaja pasivne sigurnosne sustave kao što su zračni jastuci i zatezači sigurnosnih pojaseva.



### Odvajanje akumulatora od 12 V



1. Uklonite pokrov akumulatora od 12 V u prtljažniku.
2. Otpustite minus kabel akumulatora od 12 V na vijčanom spoju i osigurajte ga od neželjenog kontakta.



## 8. Transport / skladištenje / odvuci

Transportirajte vozilo samo s objema osovinaama na vozilu za vuču ili transporterom za automobile.

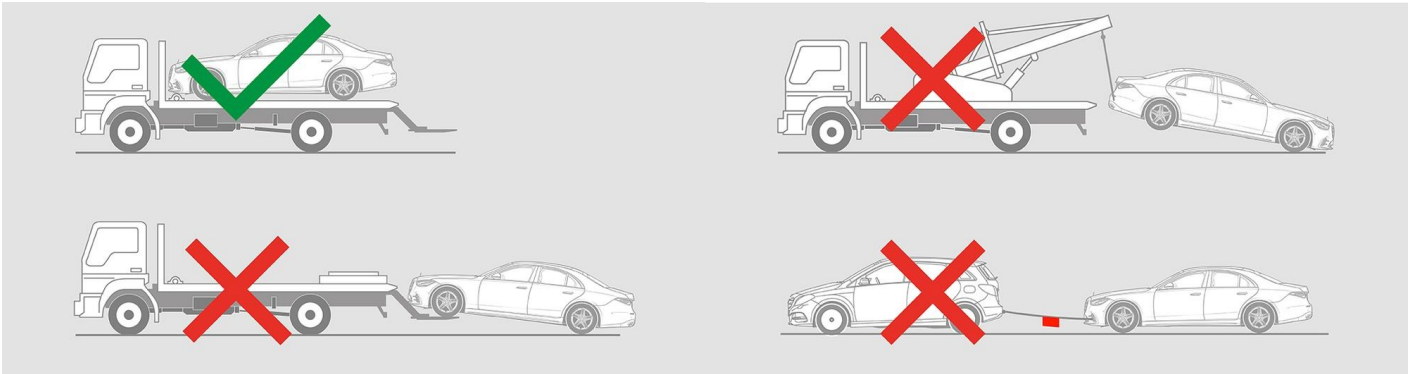

Pohranite ga na sigurnoj udaljenosti od drugih vozila.



Upozorenje: akumulator se može ponovo zapaliti

