

- ① Batterie du réseau de bord      ② Batterie additionnelle      ③ Batterie haute tension      ④ Prise de charge haute tension
- ⑤ Dispositif de coupure haute tension      ⑥ Dispositif de coupure haute tension de remplacement

 Airbag	 Générateur de gaz	 Rétracteur de ceinture	 Amortisseur à gaz	 Réservoir de carburant
 Calculateur systèmes de retenue	 Batterie 12 V	 Batterie haute tension	 Composants haute tension	 Dispositif de coupure haute tension
 Dispositif de coupure haute tension de remplacement				

Remarque: Pour obtenir de plus amples informations, veuillez consulter notre [guide de réponse d'urgence](#).



1. Identification / reconnaissance

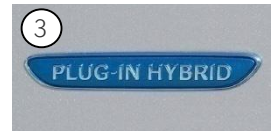
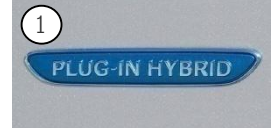
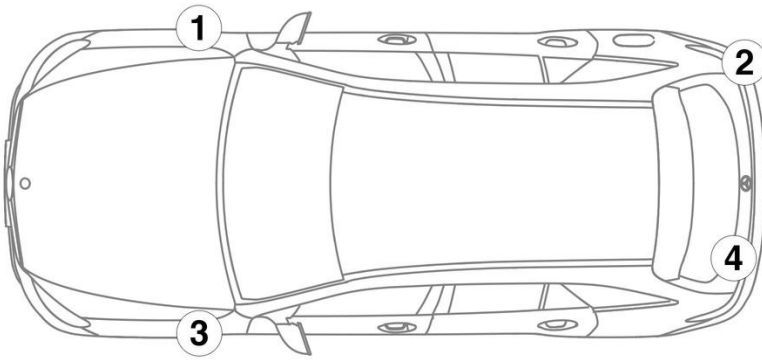



### 3. Neutraliser les dangers directs / règles de sécurité

#### Désactivation du système haute tension

Dans tous les autres cas, le système haute tension doit être désactivé comme suit :

#### Option 1: Sectionneur haute tension

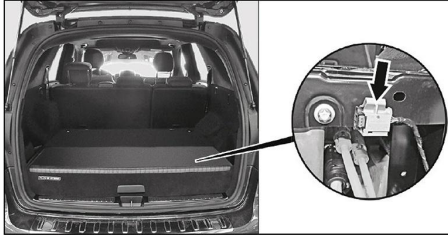

Le dispositif de coupure haute tension se trouve dans le coffre à bagages, sous le recouvrement de la batterie haute tension.

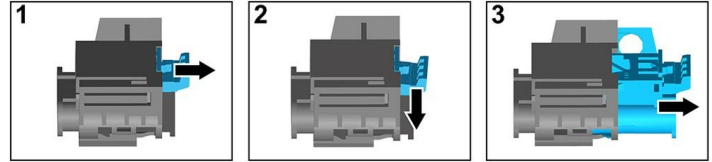

- (1) Tirer le déverrouillage
- (2) Presser le déverrouillage vers le bas
- (3) Retirer le contacteur

#### Option 2: Sectionneur haute tension secondaire



Le dispositif de coupure haute tension en alternative se trouve derrière le recouvrement, dans le montant A droit en bas. Il est identifié par une plaquette d'information.

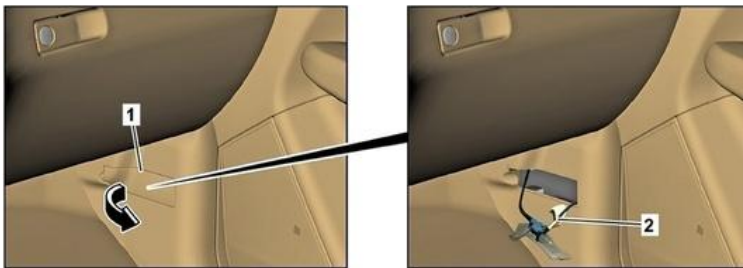

Retirer le recouvrement (1) dans le montant A / couper le câble à l'emplacement marqué (2)



Afin de s'assurer de l'absence de tension résiduelle dans le réseau haute tension, patienter env. 20 secondes après la mise hors circuit.



Les systèmes de sécurité passifs tels que les airbags et les prétensionneurs de ceinture de sécurité sont encore alimentés par le réseau de bord 12 V.



#### Couper la batterie 12 V

1. Retirer le cache de la batterie 12 V.
2. Desserrer le câble moins de la batterie 12 V au niveau du raccord vissé et le protéger contre tout contact involontaire.