















① Left-hand drive

② Right-hand drive

- | | | | | |
|-----------------------------------------------------------------------------------------------------------------------|-----------------------------------------------------------------------------------------------------------------------------------|----------------------------------------------------------------------------------------------------------------------------------------------|---------------------------------------------------------------------------------------------------------------------------|------------------------------------------------------------------------------------------------------------------------|
|  Turvapadi |  Gaasigeneraator |  Turvavöö eelpinguti |  Täiendavate turvasüsteemide juhtseade |  Aktiivne jalakäijakaitse süsteem |
|  Gaasiamort / eelpingestatud vedru |  Madalpingebater |  Akupakett, kõrgepinge |  Kõrgepinge-toitejuhe |  Kõrgepingekomponent |
|  Kaabli lõikamine |  Madalpingeseade, mis ühendab kõrgepinge lahti |  Gaasipaak koos gaasitüübi märgistusega (H ₂) |  Gaasitoru (H ₂) | |

Märkus: Lisateabe saamiseks vaadake meie [päästetööde andmelehte](#).



1. Identifitseerimine / tunnustamine

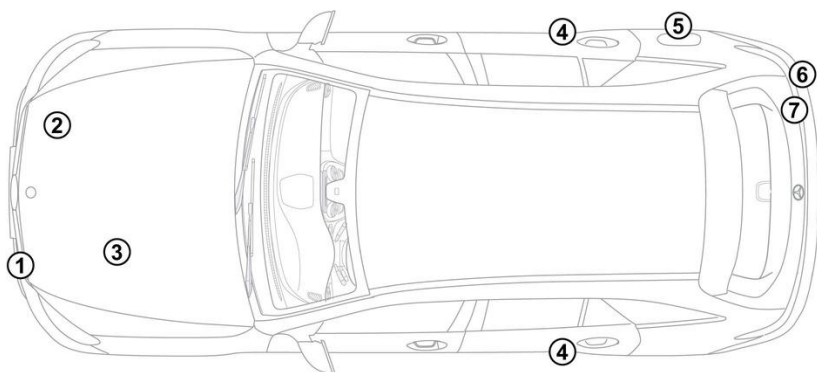

3. Otseste ohtude kõrvaldamine / ohutusreeglid

Kõrgepingesüsteemi inaktiveerimine



Hydrogen components are marked with an appropriate warning label, as are the two hydrogen lines between the fuel cell and the anode module.



Õnnetuse korral, kus turvapadjad ja turvavöö eelpingutid rakenduvad, lülitub kõrgepingesüsteem automaatselt välja.



Kõigil muudel juhtudel tuleb kõrgepingesüsteem välja lülitada järgmiselt.

Suvand 1: Kõrgepinge väljalülitusseadis

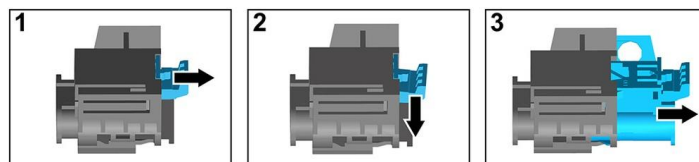
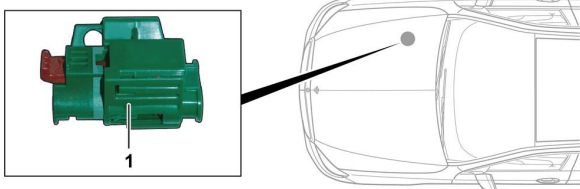

Kõrgepinge väljalülitusseadis asub mootoriruumis kõrvalistuja poolel.



- (1) Tõmmake vabastusseadist
- (2) Lükake vabastusseadis alla
- (3) Tõmmake lüliti välja



Suvand 2: Alternatiivne kõrgepinge väljalülitusseadis

Alternatiivne kõrgepinge väljalülitusseadis asub armatuurlaual kaitsmekasti katte all, juhi poolel. See on täistatud viitava sildiga.

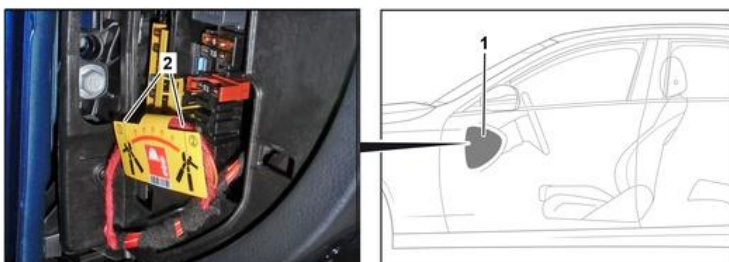

Eemaldage kate (1). Lõigake juhe markeritud kohast (2) läbi.



Tagamaks, et kõrgepingevõrgus pole jääkpinget, oodake pärast väljalülitamist ca 20 sekundit.



Passiivseid turvasüsteeme, nagu turvapadjad ja turvavöö eelpingutid, varustatakse jätkuvalt 12-voldise pardavõrgu vooluga.



12 V aku lahutamine



1. Eemaldage mootoriruumist 12-voldise aku kate.
2. Keerake 12-voldise aku miinuskaabel kruviühenduse juurest lahti ja kindlustage juhusliku kontakti vastu.