

- ① On-board electrical system battery
- ② Additional battery
- ③ High-voltage battery
- ④ High-voltage charge socket
- ⑤ High-voltage disconnect device
- ⑥ Alternative high-voltage disconnect device



Märkus: Lisateabe saamiseks vaadake meie [päästetööde andmelehte](#).



1. Identifitseerimine / tunnustamine

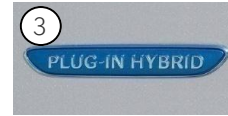
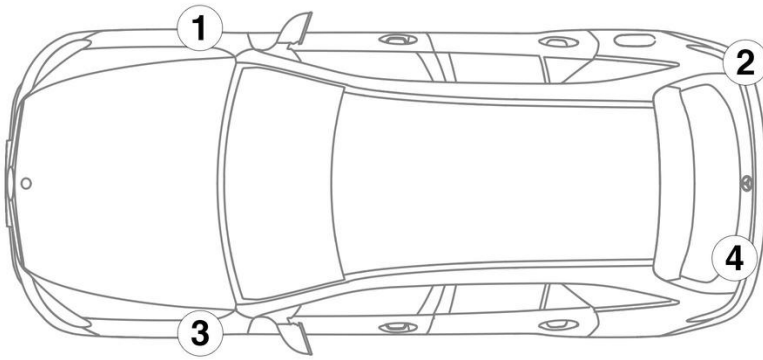

3. Otseste ohtude kõrvaldamine / ohutusreeglid

Kõrgepingesüsteemi inaktiveerimine

Kõigil muudel juhtudel tuleb kõrgepingesüsteem välja lülitada järgmiselt.

Suvand 1: Kõrgepinge väljalülitusseadis

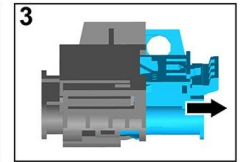
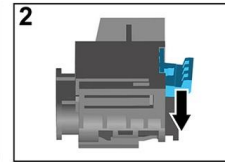
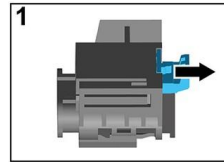
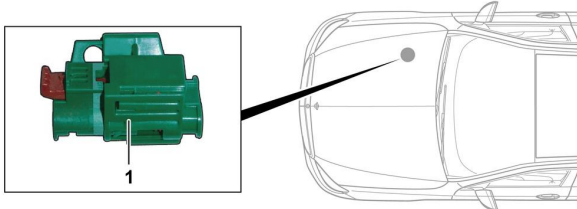

Kõrgepinge väljalülitusseadis asub mootoriruumis kõrvalistuja poolel.



- (1) Tõmmake vabastusseadist
- (2) Lükake vabastusseadis alla
- (3) Tõmmake lüliti välja

Suvand 2: Alternatiivne kõrgepinge väljalülitusseadis



Alternatiivne kõrgepinge väljalülitusseadis asub armatuurlaual kaitsmekasti kate all, juhi poolel. See on täistatud viitava sildiga.

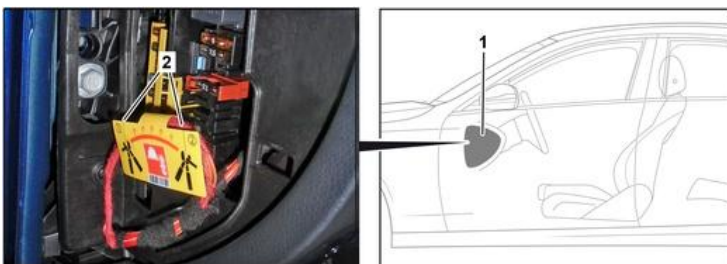

Eemaldage kate (1). Lõigake juhe markeeritud kohast (2) läbi.



12 V aku lahutamine

1. Eemaldage mootoriruumist 12-voldise aku kate.
2. Keerake 12-voldise aku miinuskaabel kruviühenduse juurest lahti ja kindlustage juhusliku kontakti vastu.

