





-  Airbag
-  Gasgenerator
-  Gurtstraffer
-  SRS Steuergerät
-  Gasdruckdämpfer / vorgespannte Feder
-  Niedervolt-Batterie
-  Hochspannungsbatterie
-  Hochspannungskabel
-  Hochspannungskomponente
-  Kabeltrennstelle
-  Hochvolt-Trennung an Niedervolt-Trennstelle

Hinweis: Weiterführende Informationen entnehmen Sie bitte unserem [Rettungsleitfaden](#).



1. Identifizierung / Erkennung

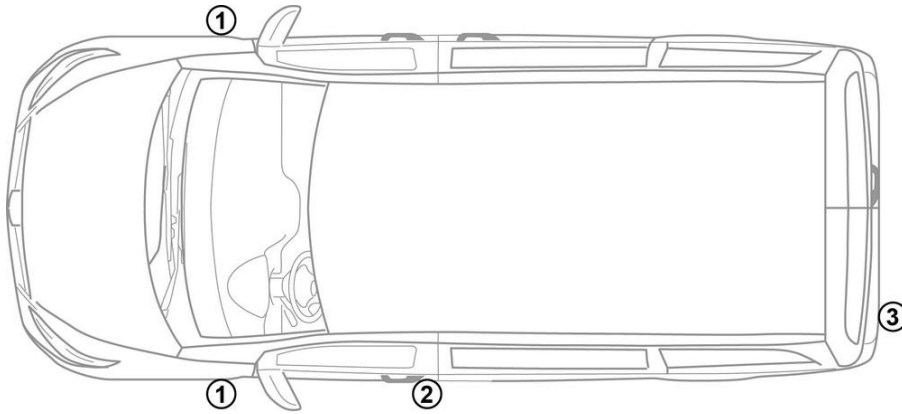

①

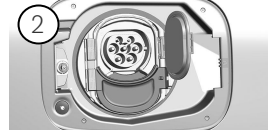

③



3. Direkte Gefahren ausschalten / Sicherheitsbestimmungen

Deaktivierung des Hochvoltsystems

In allen anderen Fällen ist das Hochvoltsystem wie folgt zu deaktivieren:

Option 1: Hochvoltabschaltvorrichtung

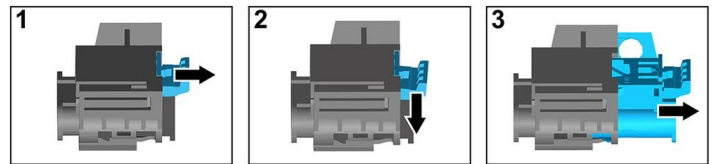
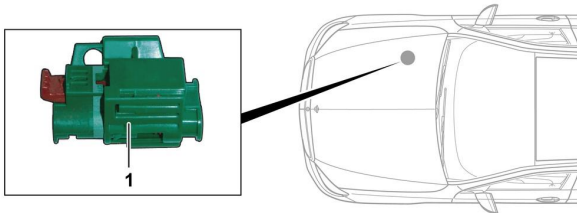

Die Hochvolt-Abschaltvorrichtung befindet sich im Motorraum auf der Beifahrerseite.



- (1) Entriegelung ziehen
- (2) Entriegelung nach unten drücken
- (3) Schalter herausziehen



Option 2: Alternative Hochvoltabschaltvorrichtung

Die alternative Hochvolt-Abschaltvorrichtung befindet sich im Sitzkasten des rechten Vordersitzes. Sie ist mit einem Hinweisschild gekennzeichnet.



Abdeckung (1) entfernen. Leitung an der markierten Stelle (2) durchschneiden.



12-V-Batterie abklemmen

- 1. Abdeckung der 12-Volt-Batterie entfernen.
- 2. Minuskabel der 12-Volt-Batterie an der Schraubverbindung lösen und gegen ungewollten Kontakt sichern.