





48 V Li-ion

12V AGM

-  Airbag
-  Gasgenerator
-  Forspænder til sikkerhedssele
-  SRS kontrolenhed
-  Gastryksdæmper/forspændt fjeder
-  Lavspændingsbatteri
-  Diesel brændstofftank



1. Identifikation / genkendelse



2

G 450 d

2. Immobilisering / Stablisering / Løft

Parkeringsbremse

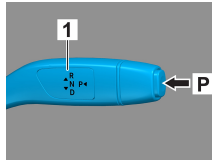
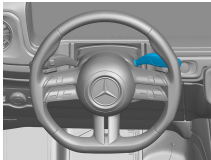

Håndbremse

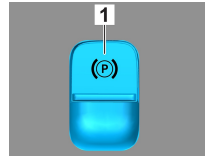
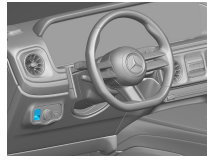

Tryk på kontakten P på gearvælgeren (1). Parke-
ringsbremsen aktiveres automatisk.

Elektrisk håndbremse (1)

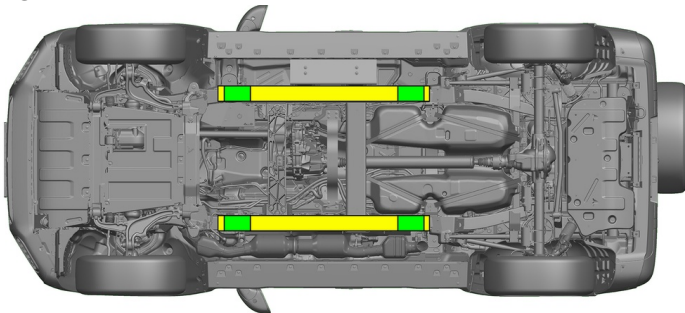

Egnede løftepunkter



Egnede stabiliseringspunkter på siden



Yderligere deformering af karme og undervogn under bjærgningen (f.eks. ved afstivning med hydraulisk udstyr) skal undgås.

3. Deaktivering særlige farer / sikkerhedsforskrifter

Slå tændingen fra:

1. Tryk på START-STOP-knappen uden at aktivere driftsbremsen.
2. Hold den elektroniske køretøjsnøgle i en afstand på mindst 5 m.

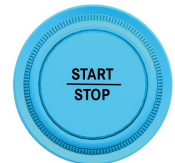
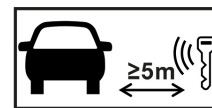

Fraværet af motorlyde betyder ikke, at køretøjet er slukket.



En genstart er mulig, indtil køretøjet tages ud af drift.



Afklemning af 48-V-batteriet

1. Afmontér bagagerummets bundplade (afskruning af de 4 fastsurringsringe), afmontér derefter div. beklædninger (C-, D-stolpe, sidebeklædning osv.) og sidevægsklædningen for at få adgang til 48-V-batteriet.
2. Løsn 48-V-batteriets minuskabel ved skrueforbindelsen, og sikr den mod utilsigtet kontakt.





Afklemning af 12-V-batteriet



1. Afmonter bagagerummets bundplade (afskruling af de 4 fastsurringsringe) for at få adgang til 12-V-batteriet.
2. Løsn 12-V-batteriets minuskabel ved skrueforbindelsen, og sikr den mod utilsigtet kontakt.



De passive sikkerhedssystemer (airbags og forspændere til sikkerhedssele) deaktiveres.

4. Adgangveje til tilskadekommande

Ved bjærgning af passagerer skal der tages hensyn til områderne på karrosseriet af højstyrkestål og komponenterne i sikkerhedsselesystemerne (især pyrotekniske elementer) som vist på side 1.

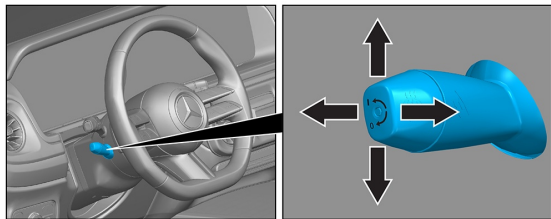

Ratindstilling

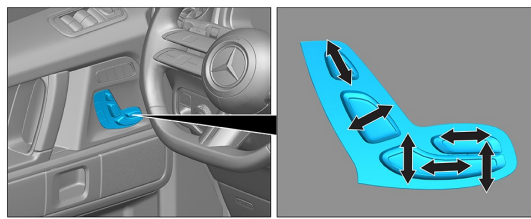

Sædeindstilling (elektrisk)



- VSG: lamineret sikkerhedsglas
- ESG: hærdet glas

5. Oplagret energi / væsker / gasser / faste stoffer

		12 V/ 48 V
		100 L
		680 ± 10 g

6. I tilfælde af brand



Brug store mængder vand (H₂O), når en køretøjsbrand skal slukkes.

7. I vand

Der er ingen fare ved, at der er spænding på karrosseriet. Efter bjærgning af køretøjet:

1. Lad vandet løbe ud af kabinen.
2. Påbegynd deaktivering af 12-/48-voltsledningsnettet (se kapitel 3).



8. Bugsering / transport / opbevaring

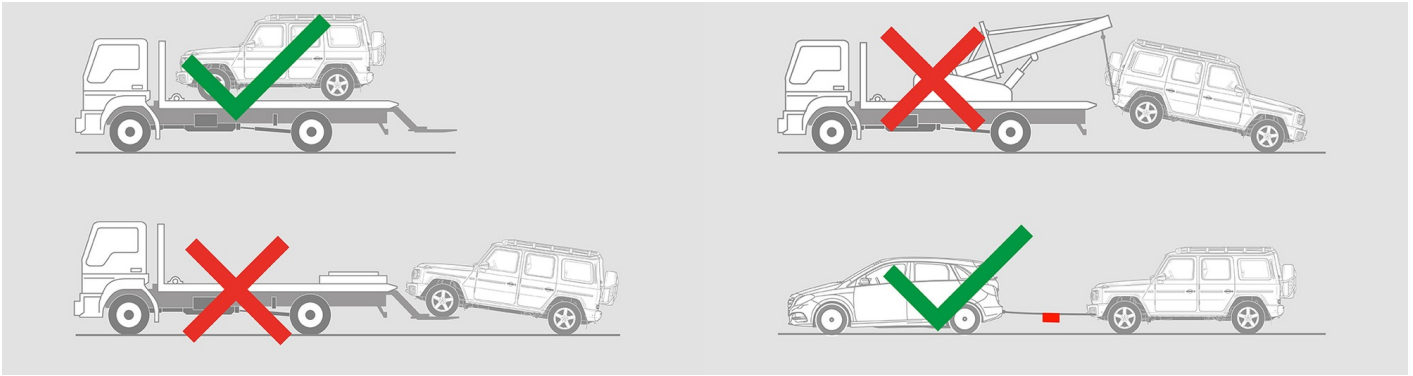

9. Vigtige ekstra oplysninger

Yderligere oplysninger findes i [Vejledning for bjærgningsfirmaer, personvogne](#).

Bemærkning: For yderligere oplysninger henvises til vores [redningsvejledning](#).

10. Piktogram information

-  Køretøj på brændstof i klasse 1
-  Generelt advarsskilt
-  Brandfarligt
-  Farligt for menneskers sundhed
-  Ætsende
-  Eksplosiv
-  Brug vand til at slukke ilden
-  Brug tørt skum til at slukke ilden
-  Brug vådt skum til at slukke ilden
-  Bagagerum
-  Fjern smart nøgle
-  Klima anlæg
-  Advarsel; lav temperatur