

- |   |   |   |   |  |
|---|---|---|---|--|
|  Airbag                          |  Gasgenerator        |  Forspænder til sikkerhedssele |  SRS kontrolenhed |  Aktivt fodgængerbeskyttelsessystem |
|  Gastryksdæmper/forspændt fjeder |  Lavspændingsbatteri |  Diesel brændstoftank          |   |  |

Bemærkning: For yderligere oplysninger henvises til vores [redningsvejledning](#).



### 1. Identifikation / genkendelse



### 2. Immobilisering / Stabillisering / Løft

#### Parkeringsbremse



#### Håndbremse

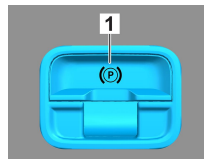

Tryk på kontakten P på gearvælgeren (1). Parkeringsbremsen aktiveres automatisk.

Elektrisk håndbremse (1)

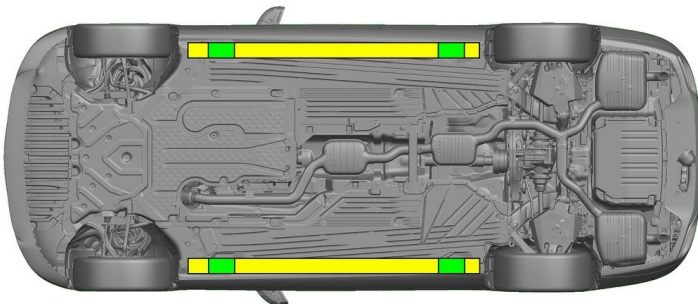

Egnede løftepunkter



Egnede stabiliseringspunkter på siden



Yderligere deformering af karme og undervogn under bjærgningen (f.eks. ved afstivning med hydraulisk udstyr) skal undgås.

### 3. Deaktivering særlige farer / sikkerhedsforskrifter

#### Slå tændingen fra:

1. Tryk på START-STOP-knappen uden at aktivere driftsbremsen.
2. Hold den elektroniske køretøjsnøgle i en afstand på mindst 5 m.



Fraværet af motorlyde betyder ikke, at køretøjet er slukket.



En genstart er mulig, indtil køretøjet tages ud af drift.



#### Afbryd 12 V-/48-V-batteriet

1. Fjern dækslet til 12-/48-voltsbatterierne i motorrummet.
2. Løsn minuskablet på 12-/48-voltsbatteriet ved skrueforbindelsen, og sikr det mod utilsigtet kontakt.



**Afbryd 12/48 V-batteriet**

1. Fjern dækslet til 12/48-voltsbatterierne i bagagerummet.
2. Løsn minuskablet på 12/48-voltsbatteriet ved skrueforbindelsen, og sikr det mod utilsigtet kontakt.



De passive sikkerhedssystemer (airbags og forspændere til sikkerhedssele) deaktiveres.

**4. Adgangveje til tilskadekommande**

Ved frigørelse af personerne i bilen skal der tages hensyn til komponenterne i sikkerhedssystemerne (især pyrotekniske elementer) i overensstemmelse med angivelserne på side 1.



Ratindstilling



Sædeindstilling (elektrisk)

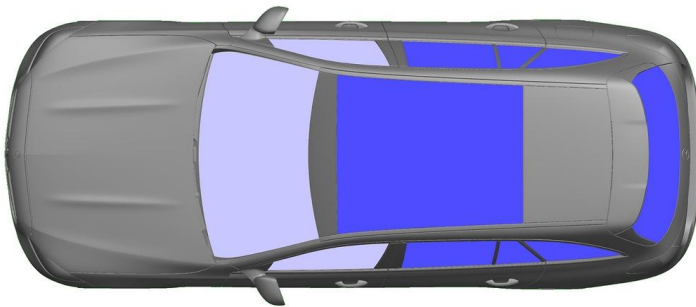

- VSG: lamineret sikkerhedsglas
- ESG: hærdet glas

**5. Oplagret energi / væsker / gasser / faste stoffer**

		12 V / 48 V
		66 L
		570 ± 10 g

**6. I tilfælde af brand**

Brug store mængder vand (H<sub>2</sub>O), når en køretøjsbrand skal slukkes.

**7. I vand**

Der er ingen fare ved, at der er spænding på karrosseriet. Efter bjærgning af køretøjet:

1. Lad vandet løbe ud af kabinen.
2. Påbegynd deaktivering af 12-/48-voltsledningsnettet (se kapitel 3).



### 8. Bugsering / transport / opbevaring

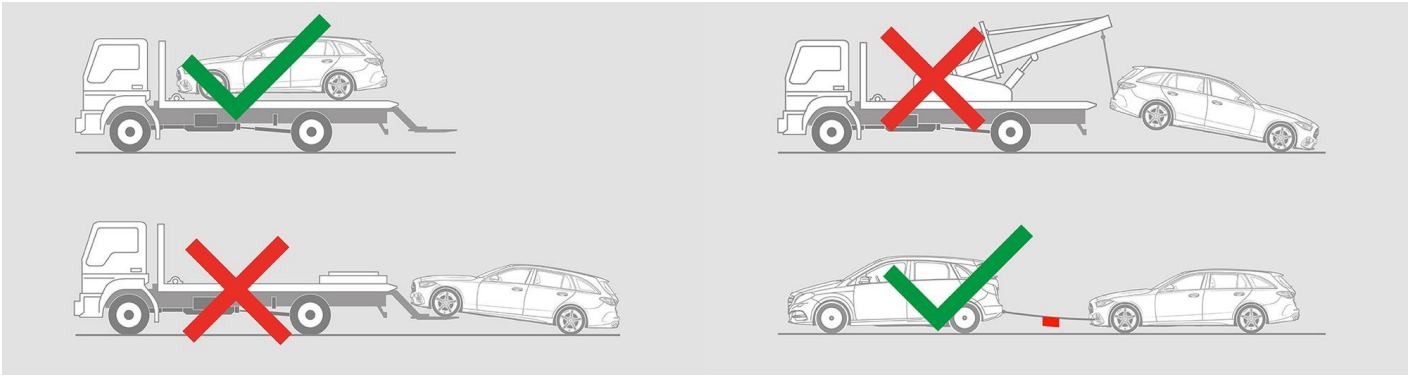

### 9. Vigtige ekstra oplysninger

Yderligere oplysninger findes i [Vejledning for bjærgningsfirmaer, personvogne](#).

### 10. Piktogram information

	Køretøj på brændstof i klasse 1		Generelt advarsskilt		Brandfarligt		Farligt for menneskers sundhed
	Ætsende		Akut toksicitet		Ekspllosiv		Brug vand til at slukke ilden
	Brug tørt skum til at slukke ilden		Brug vådt skum til at slukke ilden		Motorhjelm		Bagagerum
	Fjern smart nøgle		Klima anlæg		Advarsel; lav temperatur		