

-  Airbag
-  Gasgenerator
-  Forspænder til sikkerhedssele
-  SRS kontrolenhed
-  Gastryksdæmper/forspændt fjeder
-  Lavspændingsbatteri
-  Batteripakke, højspænding
-  Højspændingskabel
-  Højspændingskomponent
-  Kabelskæring
-  Lavspændingsenhed, der afbryder højspænding

Bemærkning: For yderligere oplysninger henvises til vores [redningsvejledning](#).

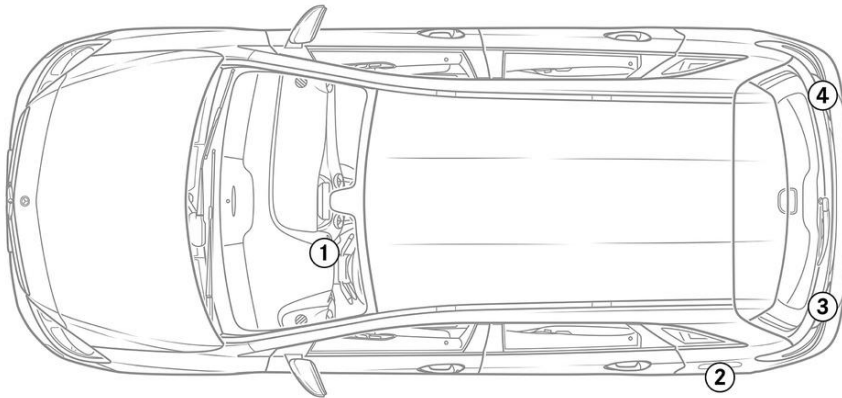

1. Identifikation / genkendelse



3. Deaktivering særlige farer / sikkerhedsforskrifter

Deaktivering af højvoltage systemet

I alle andre tilfælde skal højvoltage systemet deaktiveres på følgende måde:

Mulighed 1: Højvoltsafbryder



Højvoltsfrakoblingsenheden er placeret til venstre set i kørselsretningen bag instrumentpanelets sidebeklædning.

Fjern instrumentpanelets sidebeklædning (1) / træk stikket (2) af

Mulighed 2: Alternativ højvoltsafbryder



Den alternative højvoltsfrakoblingsenhed sidder under fodrumsafdækningen i passagersiden. Den er mærket med en mærkat.

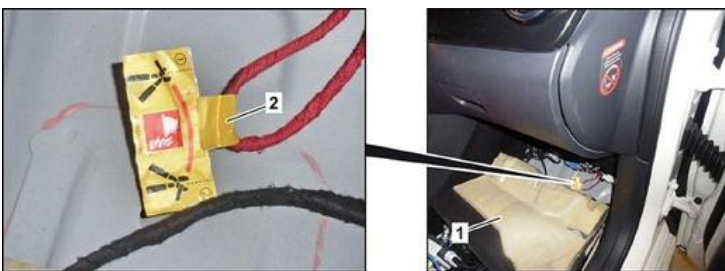

Klap fodrumsafdækningen (1) bagud/klip ledningen over på den markerede position (2)



For at sikre, at der ikke er restspænding i højspændingsnettet, skal du vente cirka 20 sekunder efter afbrydelsen.



De passive sikkerhedssystemer såsom airbags og forspændere til sikkerhedssele forsynes fortsat med strøm fra 12-voltsledningsnettet.



Afbryd 12 V-batteriet



1. Fjern dækslet til 12-voltsbatteriet i motorrum.
2. Løsn minuskablet på 12-voltsbatteriet ved skrueforbindelsen, og sikr det mod utilsigtet kontakt.