

- ① Akumulator (12 V), Vozila z volanom na levi strani
- ② Akumulator (12 V), Vozila z volanom na desni strani
- ③ Visokonapetostni akumulator
- ④ Naprava za izklop visokonapetostnega sistema
- ⑤ Visokonapetostna polnilna vtičnica

- | | | | | |
|--|---|---|--|--|
|  Zračni meh |  Plinski generator |  Zateznik varnostnega pasu |  Plinski tlačni blažilnik |  Krmilnik zadrževalnih sistemov |
|  Akumulator (12 V) |  Visokonapetostni akumulator |  Visokonapetostne komponente |  Naprava za izklop visokonapetostnega sistema | |

Napotek: Za več informacij si oglejte naš [reševalni vodnik](#).



1. Identifikacija / prepoznavanje

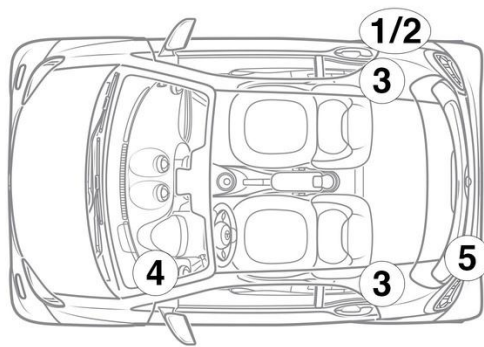

3. Onemogočanje neposrednih nevarnosti / varnostni predpisi

Deaktiviranje visokonapetostnega sistema

V vseh drugih primerih je treba visokonapetostni sistem deaktivirati na naslednji način:

Visokonapetostna odklopna naprava

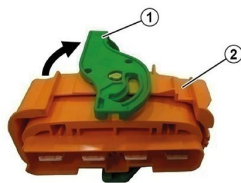
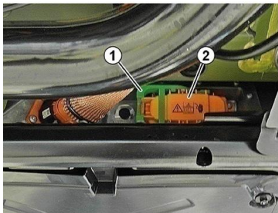

Naprava za izklop visokonapetostnega sistema je nameščena na spodnji strani visokonapetostnega akumulatorja v smeri vožnje zadaj desno.

Sprostitev zaklepa (1) na vtiču (2)/izvlek vtiča (2) iz visokonapetostnega akumulatorja



Da zagotovite, da v visokonapetostnem omrežju ni preostale napetosti, po izklopu počakajte približno 20 sekund.



Pasivne varnostne sisteme, kot so zračne blazine in zategovalnik varnostnega pasu, še naprej napaja 12-voltni električni sistem vozila.



Odklop 12-V akumulatorja

1. Odstranite pokrov 12-V akumulatorja.
2. Odvijte negativni kabel 12-V akumulatorja na vijaknem priključku in ga zavarujte pred nenamernim stikom.