





- ① Batterie du réseau de bord
- ② Batterie additionnelle
- ③ Batterie haute tension
- ④ Dispositif de coupure haute tension

 Airbag	 Générateur de gaz	 Rétracteur de ceinture	 Amortisseur à gaz	 Renfort de carrosserie
 Réservoir de carburant	 Calculateur systèmes de retenue	 Batterie 12 V	 Batterie haute tension	 Composants haute tension
 Dispositif de coupure haute tension				

Remarque: Pour obtenir de plus amples informations, veuillez consulter notre [guide de réponse d'urgence](#).



1. Identification / reconnaissance

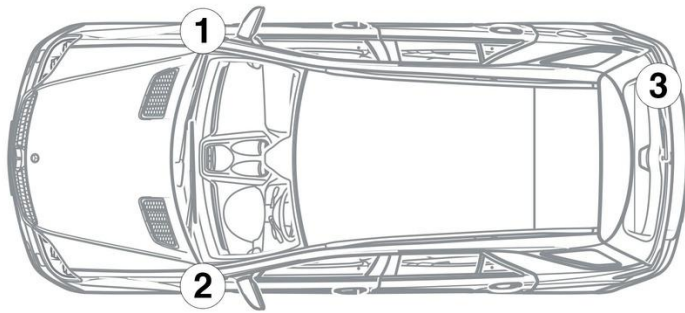

3. Neutraliser les dangers directs / règles de sécurité

Désactivation du système haute tension

Dans tous les autres cas, le système haute tension doit être désactivé comme suit :

Option 1: Sectionneur haute tension



Le dispositif de coupure haute tension se trouve accolé à la batterie haute tension, à droite à l'arrière, vu dans le sens de marche.

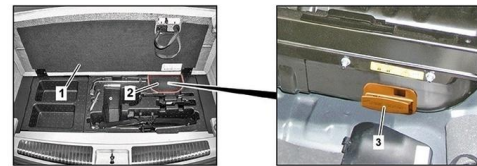

Relever le plancher du compartiment de chargement (1) / retirer le recouvrement (2) / décaler le contacteur (3) vers la droite et le retirer de la batterie haute tension



Afin de s'assurer de l'absence de tension résiduelle dans le réseau haute tension, patienter env. 20 secondes après la mise hors circuit.



Les systèmes de sécurité passifs tels que les airbags et les prétensionneurs de ceinture de sécurité sont encore alimentés par le réseau de bord 12 V.



Couper la batterie 12 V

1. Retirer le cache de la batterie 12 V.
2. Desserrer le câble moins de la batterie 12 V au niveau du raccord vissé et le protéger contre tout contact involontaire.